



PRODUCT CATALOGUE

Modernisation Solutions

Drives

Sensors

Pushes & Displays

Lift Components

Control Components

TAYLOR
L I F T S
PRODUCTS AND TECHNICAL SERVICES

Who are we?

Established in 2008 by Richard Taylor, the aim was simple; to provide technical expertise to lift companies.

Working nationwide, we provide a bespoke supply & fit service, with a rapid response time and professional qualified engineers.

We are UK distributors for Gefran, Stem & SMS, and supply a large range of products. We continually strive to offer the best quality products to the UK lift market.

Whether its a full lift modernisation package, or supply of a part, we are here to help.



Nationwide services



Professional & Qualified Engineers



Fast Response Times



Expert Advice

GEFRAN
BEYOND TECHNOLOGY

VEGA

SMS



Prosis[®]
Electronics & lift

Contact us

www.taylorlifts.co.uk

0115 714 1113

Taylor Lifts, Unit 3, Canalside Industrial Park, Kinoulton Road, Cropwell Bishop, Nottingham, NG12 3BE

Located in Cropwell Bishop, Nottingham, we can offer nationwide services, and next day delivery on parts.



Services

Troubleshooting & Repairs

If you have a troublesome lift, Taylor Lifts can provide an engineer to take a look at the problem and spend time to get the fault resolved.

We can offer:

Expert knowledge on most control systems

On site analyst to diagnose and repair

Inspection and servicing of faulty parts

Fast response and turnaround

Lift Modifications

All offered with Supply & Fit service

Add on VVVF Inverters or VVVF conversions from old technologies, to the latest in motor drives interfacing with the existing control panel

Retro-fit and interfacing DDA solutions to an existing installation

Doorgear upgrades

Indicator and pushbutton upgrades

Shaft mapping with system switching replacement

Energy efficiency improvement via regeneration back to mains

Testing

Control Panel Replacement

Complete lift control panel replacement, bespoke in house design for simple goods only, to complete passenger systems, traction, hydraulic, group or simplex.

Supplied and fitted to an exceptional standard

Set up and fine tuned ready for testing

Experience in replacement of existing MRL control systems (Kone, Orona, Otis, Schindler, Thyssen and many more) with UK designed and manufactured panels.



Spot the logo? It means that not only can we supply a product, but we can also provide a trained engineer to fit it on site!

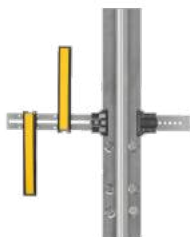

Modernisation Solutions

- 7 Control Systems
- 8 VVVF Conversions
- 9 Doorgear Replacement
- 10 Shaft Mapping
- 11 Handwinding Positional
- 12 Car Lighting
- 13 Shaft Lighting
- 14 Brake Monitoring
- 15 Limit Brackets
- 16 Pushes & Display Packages

Drives

- 18 Gefran ADL300A
- 22 Gefran ADL550
- 24 Gefran ADL550 ICE
- 25 Dynamic Braking Resistors
- 26 SMS Soft Starters
- 27 Regeneration Systems
- 28 Encoders

Sensors

- 30 Stem whole system
- 31 Hall Effect Sensors
- 32 Reed Switch Sensors
- 33 Bistable Sensors
- 34 Limit Switches
- 35 Magnets
- 37 Fixing Kits



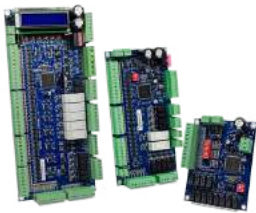

Pushes & Displays

- 40 Displays
- 42 Buttons
- 44 Fixtures

Lift Components

- 46 Control Gear
- 47 Cable
- 48 Terminal Boxes
- 49 Car Top Control
- 50 Autodialers
- 52 Detector Edges
- 53 Air Purifier

Control Components

- 55 Control Boards
- 57 NAT10
- 58 NT10
- 59 NT15
- 60 NBC 12 Battery Chargers
- 62 NC80
- 63 NC80 IP67
- 64 NC85
- 65 NC96
- 67 NCUM20
- 68 NCUM50
- 69 NCBM01

Looking for a part and can't find it in our catalogue?

Simply email us a photo of the part you require, and one of our dedicated team will do their best to source it for you!

enquiries@taylorlifts.co.uk

Modernisation Solutions

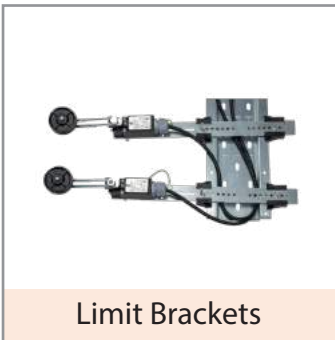
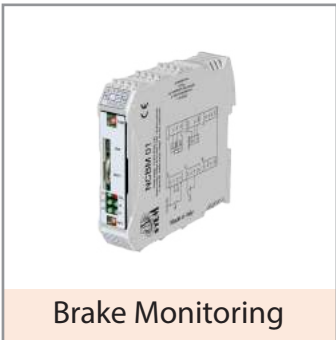



Taylor Lifts offer a complete control system package, from project management to a supply and fit service.

Taylor Lifts control panels are manufactured in house utilising a SMS microprocessor control board and high quality control gear selected from Omron, Telemecanique, Gefran ranges.

Taylor lifts can supply a full range of control systems from simple goods only lifts to complex group systems, traction or hydraulic including MRL replacement panels



In conjunction with the Taylor Lifts Control Systems the following can also be provided:

- Car Operating Stations
- Landing Push Stations
- Position Indicators
- Car & Shaft Lighting
- Complete Door operators and Detector Edges

Modernisation Solutions | VVVF Conversion

Taylor Lifts offer a complete VVVF supply & fit package retaining the existing control system and upgrading the Inverter drive enhancing ride quality and floor levelling.

It can be applied to existing VVVF systems or older single speed and two speed motor systems.

This service offers a quick turnaround compared to a complete controller replacement (normally one day) reducing customer inconvenience.

This style of conversion can be applied to pump motors on hydraulic lifts reducing starting and transient currents experienced with Direct on Line or Star/Delta starting. This will lead to greater energy efficiency and ride comfort.

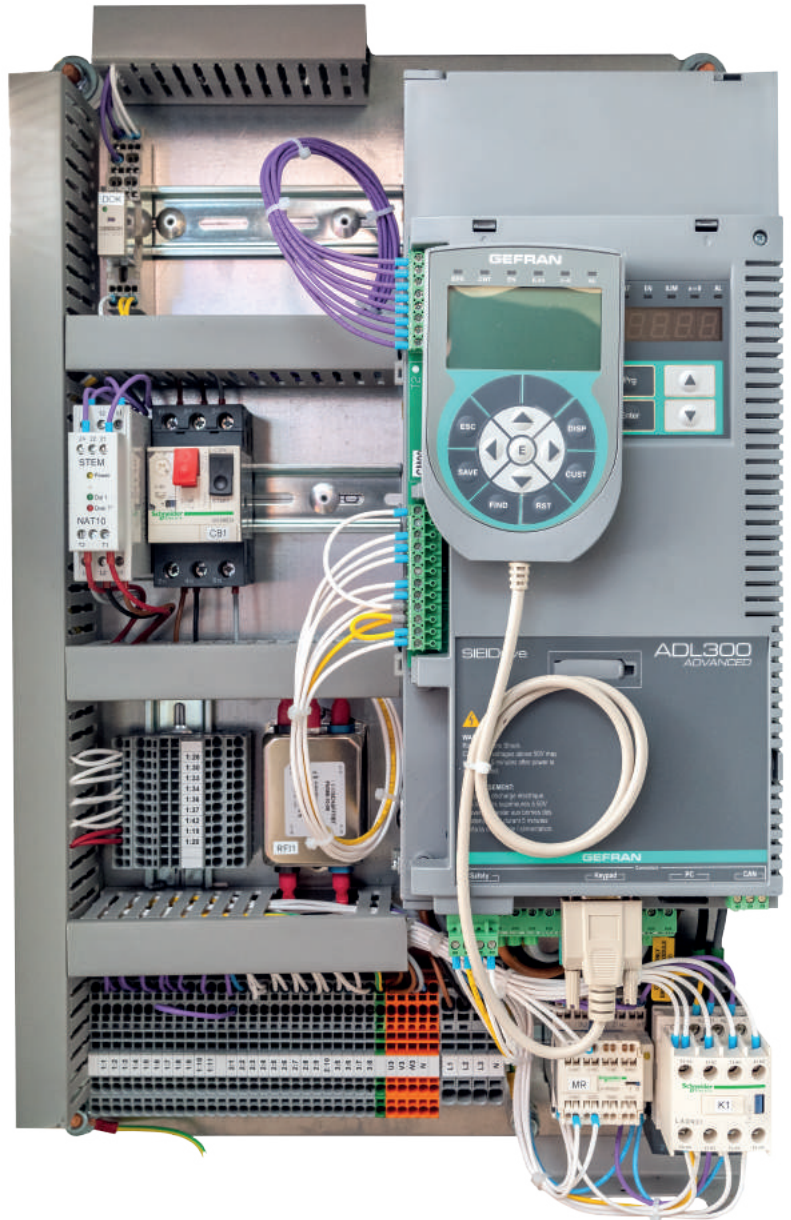

A full site survey can be carried out prior to work commencing, or the interface can be designed according to data sheets. It is essential that copies of the original control panel wiring diagrams are provided to ensure compatibility and maintain a safe working system.

Door Modification System | Modernisation Solutions

Taylor lifts are proud to offer their Doorgear rmod system. The system replaces existing electronic controls and the door motor but retains much of the existing mechanics allowing a simple replacement procedure whilst upgrading the speed control and reliability of the system.

The VEGA control box contains all the features expected of a modern door operator including:

- Encoder feedback, self-learning, to give limit free control.
- Re-opening via torque limiting,
- Reduced torque (nudge) control.
- Emergency supply operation

Replacement pulleys and belts to give the correct speed ratio are included in the package to suit numerous current and older door operators.

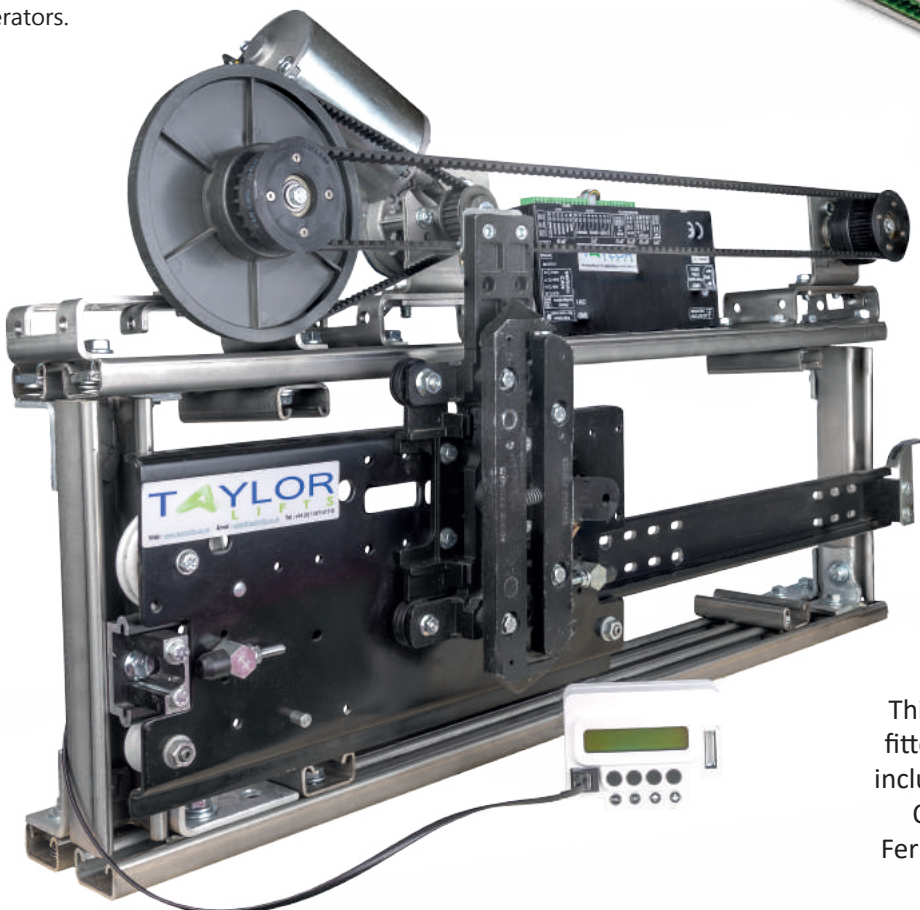

This system has been successfully fitted to a range of door operators including systems manufactured by; Otis, Kone, Schindler, Selcom, Fermator, Propbrook, GAL and IGV.

Modernisation Solutions | Shaft Mapping

Taylor Lifts offer a system for replacing existing tapeheads and vane operated positioning systems.

The system offers a solution where there is no contact between magnet and sensor, therefore reducing wear and noise, increasing lifespan and reliability.

The system has no limitation regarding number of floors and will operate up to a speed of 2m/s.

There is an option of a 12V battery backed supply for handwinding/lowering purposes.

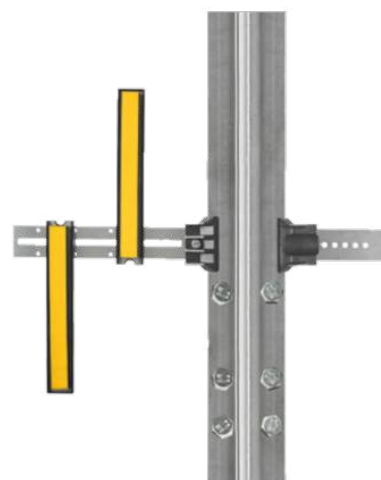

Handwinding Positional | Modernisation Solutions



Designed and manufactured by Taylor Lifts the system can be fitted independently of the existing control panel by the addition of a set of car mounted proximity switches using binary count to give the lift position.

As the unit is fitted with an indicator encoder it can be used to drive car and landing position indicators, via CAN bus, from the Taylor Lift range of components including a speech synthesiser.

12V battery backed supply included.



Modernisation Solutions | Car Lighting

Taylor Lifts LED vandal resist light box is 660mm long x 290mm wide x 40mm deep and is an ideal energy efficient way of replacing existing fluorescent tubes.



The tray has 5 pads giving a total of 960 LEDs. The tray is manufactured from 2mm 304G stainless steel and of vandal resistant design. The lens is 4mm polycarbonate and fire resistant.

The pads or individual strips up to 1000mm in length, can be used without the housing and fitted into the existing car light box. Each 500mm strip produces approximately 75 lux when fitted in a 630kg car.

Supplied with 12V battery back-up for use as emergency lighting, which gives in excess of 3 hours light.



Shaft Lighting | Modernisation Solutions

Taylor Lifts offer a flexible LED Shaft Lighting system complete with emergency lighting battery back-up if required.

The LED light twin strips come in 500mm and 1000mm lengths. They can be mounted using the bracketry supplied with the system or can be fitted into the existing light fittings.

As a general rule the light strips should be installed at 3m intervals for every 1m strip to achieve the necessary lighting levels.

Option for 12V battery back-up for use as emergency lighting.

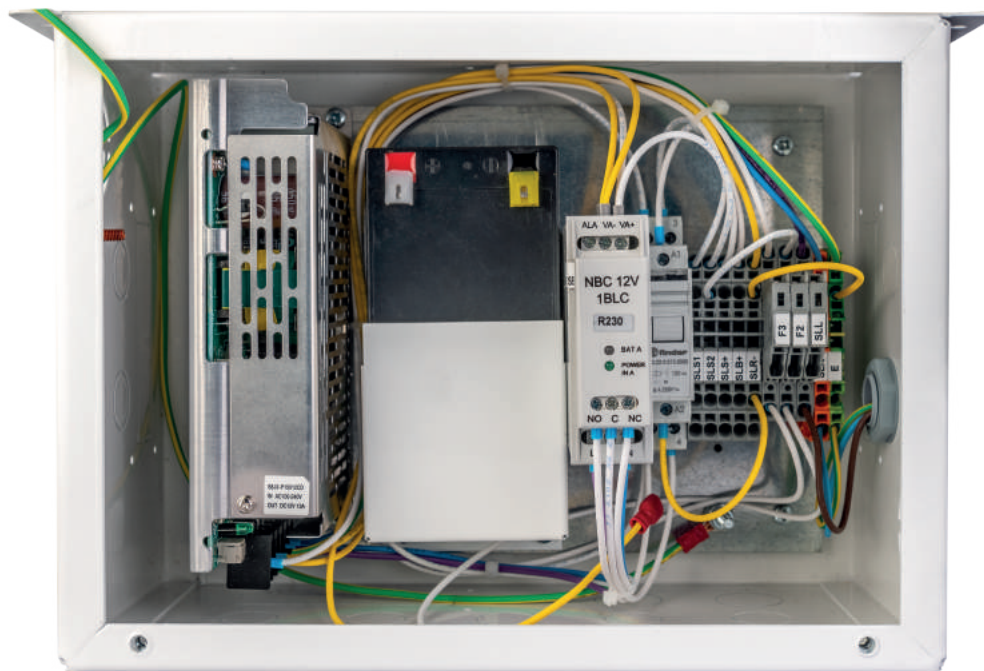



Modernisation Solutions | Pushes & Display Packages

Taylor Lifts offer a range of quality UK custom made Stainless Steel Car Operating Stations, Landing Push Stations and Digital Indicator Enclosures. All units offer vandal resistant secure fixings.

The base product range is as follows:-

- Surface Mount
- 2mm 304G Brushed Finish Stainless Steel
- Vandal Resistant Fixings



- A complete design service is offered to suit site requirements with bespoke design options.
- Standard fittings include VEGA pushbuttons with indicators coming from either VEGA or Digital Advanced Controls ranges.



ADL300A



ADL550



ADL550 ICS

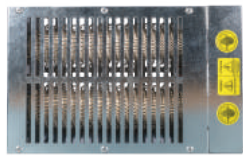

Braking Resistors



Soft Starters



Regeneration System



Encoders

ADL 300A - COMPACT DESIGN

I/O MANAGEMENT

ADL300A , optional cards on request:

| | Description |
|---------------------|--|
| EXP-IO-D4-ADL | 1DI (Enable) + 2 (Prog.DI) + 2 (RO) |
| EXP-IO-D5R3-F-ADL | 1DI (Enable) + 5 (Prog.DI) + 3 (RO) |
| EXP-IO-D6A4R2-F-ADL | 1DI (Enable) + 6 (Prog.DI) + 2 (AI) + 2 (AO) + 2 (RO) |
| EXP-IO-D8R4-ADL | 1DI (Enable) + 8 (Prog. DI) + 4 (RO) |
| EXP-IO-D8A4R4-ADL | 1DI (Enable) + 8 (Prog. DI) + 2 (AI) + 2 (AO) + 4 (RO) |
| EXP-IO-D12A2R4-ADL | 1DI (Enable) + 8 (Prog. DI) + 4 (DO) + 2 (AI) + 4 (RO) |
| EXP-IO-D16R4-ADL | 1DI (Enable) + 12 (Prog. DI) + 4 (DO) + 4 (RO) |

Standard configuration
 8 programmable digital inputs
 4 programmable relay outputs

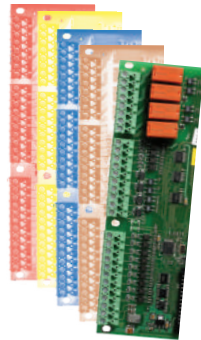

ENCODER MANAGEMENT

The ADL300 interfaces with all the main feedback devices:

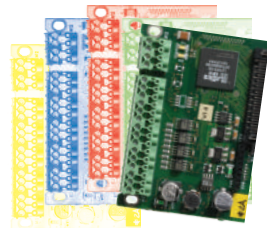

ADL300A optional cards on request:

| | Description |
|-----------------------|---|
| EXP-DE-I1R1F2-ADL | Digital encoder 3 Channels card + Repeat + 2 Freeze |
| EXP-EN/SSI-I1R1F2-ADL | Sinusoidal encoder card - Absolute EnDat + Repeat + 2 Freeze |
| EXP-HIP-I1R1F2-ADL | Hiperface encoder 3 Channels card + Repeat + 2 Freeze |
| EXP-SE-I1R1F2-ADL | Sinusoidal encoder 3 Channels card + Repeat + 2 Freeze |
| EXP-SESC-I1R1F2-ADL | Sinusoidal SinCos encoder 3 Channels card + Repeat + 2 Freeze |
| EXP-SESC-I1R1-V-ADL | Sinusoidal SinCos encoder 3 Channels card+ Repeat (VGAconnectors) |



INTEGRATED KEYPAD

The integrated programming keypad allows fast programming and immediate start-up.

SD CARD PORT

The SD memory card makes saving and loading data and configurations with the ADL300 very simple.

“SAFETY” INPUTS

For use with a single output contactor or in contactorless mode.

LIFT CONTROL SYSTEM

Basic and advanced lift functions are incorporated in a single product, to ensure maximum comfort for all systems at all times:

- Speed control: EFC (Elevator Floor Control) function: separate function for independent management of short floors, landing zone, re-starting with lift not at floor and automatic deceleration point calculation.
- Position control: EPC (Elevator Positioning Control) function: separate function for independent management of direct arrival at the floor with internal position regulator and saving of floor distances (system autotuning).
- Lift sequence: Typical sequence of input/output signals used in civil lift engineering applications such as I/O management, braking, output contactor and door control.
- Parameters in linear unit: Possibility of selecting different engineering units (also with values for the US) for the main movement parameters, rpm (fpm) or m/s for speed, m/s², m/s³ for cabin acceleration.
- Lift mechanical parameters: Mechanical system parameters such as pulley diameter and speed ratio for converting system units and weights, system for calculating inertia and speed regulation for the desired response.
- Ramp generation: Independent configuration of acceleration and deceleration ramp parameters and of the 4 jerk values for maximum travelling comfort in the lift cabin. Two independent S-shaped ramps, selectable via digital input with 4 independent jerk settings. Dedicated deceleration ramp corresponding to the stop command.

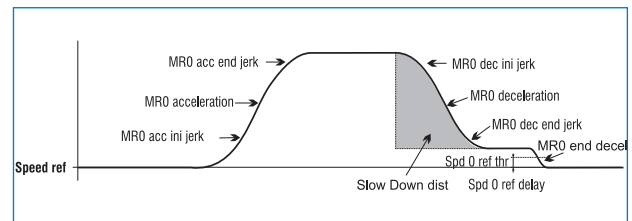
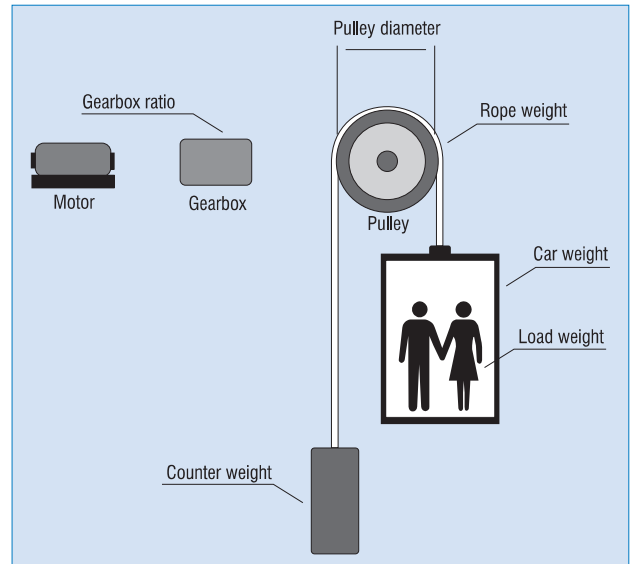

OPTIONAL PROGRAMMING KEYPAD

The keypad can be used remotely from distances of up to 15 m. A 70 cm-long connection cable is supplied as standard.



- 5 line x 21 character display
- Alphanumeric plaintext
- Complete information regarding each parameter
- Fast navigation keys
- Key for displaying the last 10 parameters that have been changed
- DISP key for rapid display of operating parameters
- Uploading-Downloading and saving of 5 complete sets of drive parameters

CONFIGURATION TECHNOLOGY

The ADL300 is fitted with RS232 serial communication with Modbus RTU protocol.

FIELDBUSES

The ADL300 integrates the most advanced fieldbus technology used in the lift sector:

- DCP3 for use in EFC (Elevator Floor Control) mode
- DCP4 for use in EPC (Elevator Positioning Control) mode
- CANopen and CANopen Lift (CiA@417) for lift control systems.

BACK-UP POWER SUPPLY

The ADL300 guarantees operation even in the event of a power failure. It features an automatic return-to-floor function managed by an external device such as UPS or buffer battery via a singlephase 230V AC power.

In the last decade the elevators have been under a tremendous evolution from the technology standpoint like never before. Safety, comfort travel, efficiency, reliability, remote access combined with the use of smartphones and tablets are the major changes that we daily experience versus the old generation systems.

Gefran has developed the **new ADL500 inverter series specific for elevators EN81-20 / EN81-50 certified.**



The series is composed of three lines ADL550, ADL530 and ADL510 designed to answer the requirements of high rise, medium rise and low rise buildings, without to forget the big market of the modernization.

ADL510

Designed to be simple and easy to install in case of asynchronous motors typical of low-rise buildings or modernization both in open and close loop.

ADL530

Designed to control both geared and gearless motors integrated On-board Universal encoder interface (EnDat, SinCos, BiSS and Digital Incremental) and integrated CAN port for communication by CAN Open 301 and CAN Open Lift 417 are ready to use.

ADL550

With the advanced safety functions, Safe Torque Off SIL3 (Phase contactor-less), Safe Brake Test (SBT) to check the motor brakes effectiveness, and the Electronic Brake Control (EBC) SIL3 that replaces the electro-mechanical brakes contactors by internal electronics (Brake contactor-less). Elevator Positioning Control (EPC) that allows to have a better comfort with the direct approach and precise floor levelling even for very high demanding elevators. Stand-by management, where the power part of the drive is shut off to eliminate the energy consumption during the idle state.

ADL550-ICS

The Integrated Control System creating one single environment between the inverter and the control card, optimizing the commissioning and the start-up of the electronic parts of the elevator.

| | HIGH RISE | MID RISE | LOW RISE | HOME LIFT |
|------------------|--|---|---|--|
| Regenerative |  <p>AFE200 + ADL500</p> | | | |
| Non Regenerative |  <p>ADL550</p> |  <p>ADL530</p> |  <p>ADL510</p> |  <p>ADL550-2M</p> |

INTEGRATED SAFETY FUNCTIONS

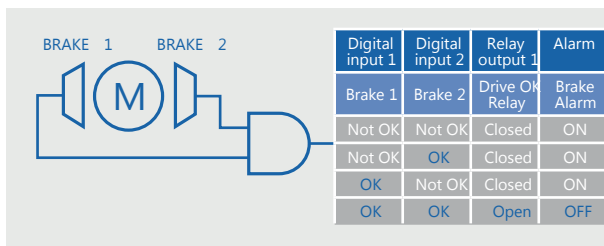

UCM (UNINTENDED CAR MOVEMENT)

As reported in the paragraph 5.6.7 in the EN81-20, it is requested the immediate stop of the car in case of movement with doors open. To answer this requirement, Gefran introduced the continuous independent monitoring of the brakes feedback.

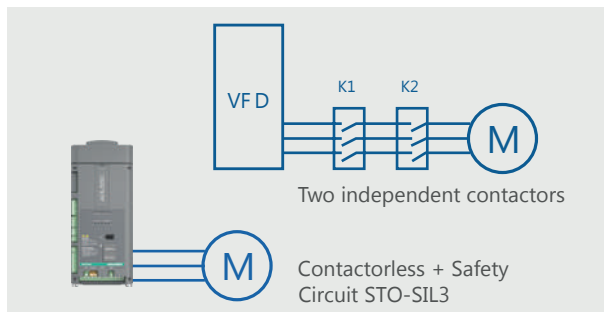

STO (SAFE TORQUE OFF) SIL3

Based on the paragraph 5.9.2.5 in the EN81-20, in order to cut the motor power supply that cause the motor rotation it is requested to use two independent contactors that increase the cost of the installation and the noise of the switch. Gefran integrated the STO-SIL3 certified safety circuit that allows to avoid the installation of external contactors between the motor and the inverter.

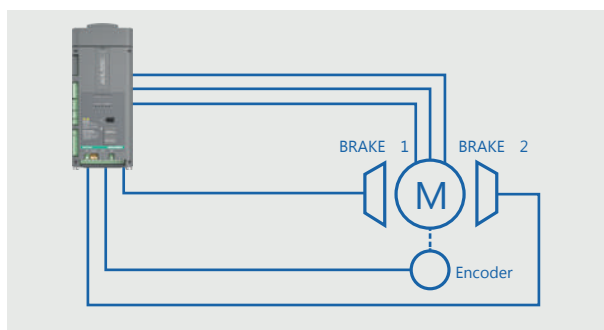

SBT (SAFE BRAKE TEST)

Gefran has developed a specific function to test the holding torque of the motor brakes (operational or holding brake) in motor with encoder, both with the two brakes active or for each brake independently. If, during the test, the rotor moves beyond an acceptable range an alarm is raised

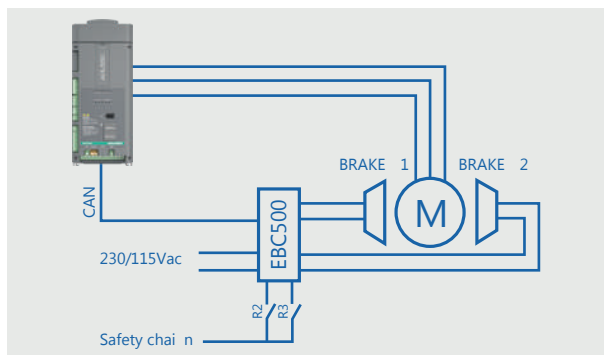

EBC500 - ELECTRONIC BRAKE CONTROL SIL3

The EBC500 (Electronic Brake Control) is an external optional module designed by GEFRAN for the new inverter family ADL550/ADL550-ICS, that enable the safe control and monitoring of the motor's brakes. The traditional electro-mechanical brakes contactors, subject to wear and failures are replaced by internal electronics featuring longest lifetime (ZERO CONTACTORS SOLUTION) reducing the maintenance cost and increasing the durability of the service life of the brakes

The ADL500 series introduce operators in a new era of inverter management. Together with the traditional approach by cabled keypad or cabled PC, that oblige the operators to be on-site; Gefran introduces a new generation of inverter management based on the modern telecommunication technology.

Thanks to GF_Liftouch, the web application designed by Gefran, operations like the start-up, tuning, monitoring and the alarm check, can be easily achieved by mobile phone or tablet with a simple WI-FI connection, or can be fulfilled from remote, thanks to the Gefran Portal, the cloud infrastructure that allows customers to create their own Elevator Management System.



GF_Liftouch WebApp connection

> Direct Wi-Fi connection using Wi-Fi Drive link optional module (1).

> Direct connection or through LAN using the Modbus TCP protocol (2).

> Remote connection with drive connected to a gateway with SIM card and data connection. By logging onto the Gefran portal, it is possible to monitor and manage the in-field drives and access them directly (3).

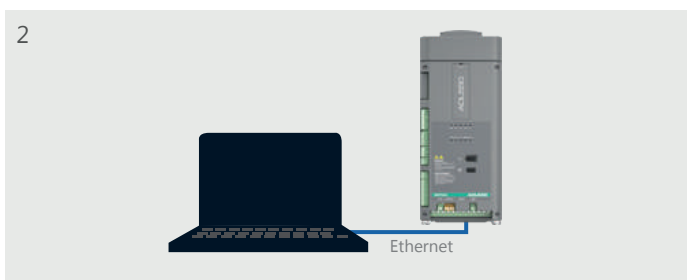

GF_DriveLabs Configuration tool

> Direct connection or through LAN using the Modbus TCP protocol (2)



EXPANSION CARDS

EXTRA I/O CONFIGURATION

All in one board with:

- > 4 Digital Inputs
- > 2 Relay Output

OR

DCP3 and DCP4 Protocols
DCP3 for use in EFC (Elevator Floor Control) mode.

DCP4 for use in EPC (Elevator Positioning Control) mode.

DCP 3 *DCP 4*

OPTIONAL PROGRAMMING KEYPAD

The optional programming keypad is easy to use and always ready.

GREEN SOLUTIONS AND FEATURES

- > Regenerative configuration with the AFE200 external modules.
- > Reduced consumption thanks to system stand-by management logic combined with external +24Vdc power supply.
- > Hybrid power supply with supercapacitors.
- > Regenerative energy calculation.



INPUT / OUTPUT

| | ADL550 | ADL530 | ADL510 |
|--------------------|------------|------------|------------|
| Analog input | 2 | 2 | 1 |
| Digital input | 8-1 Enable | 8-1 Enable | 8-1 Enable |
| Digital output | 4 (Relays) | 4 (Relays) | 4 (Relays) |
| Fast digital input | 2 | - | - |

USB PORT



- > Uploading and downloading parameters file.
- > Motor selection and upload of data plate information from database.
- > Uploading languages and SW applications on board the drive.
- > Smart FW update.

UNIVERSAL INTEGRATED MULTI-ENCODER

Selects the encoder type from the parameter without adding dedicated boards, such as: SinCos, Endat, Biss, Digital Incremental.

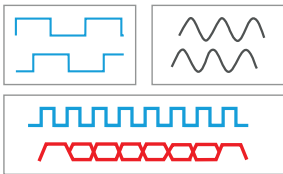

Wi-Fi COMMUNICATION

Plug-in for optional Drive Link Wi-Fi module for wireless communication via GF_Liftouch APP.



ETHERNET PORT

Built-in Ethernet communication with Modbus TCP protocol for direct/LAN connection to monitor and configure the drive or for remote gateway connection.

CANopen PORT

- > CANopen 301.
- > CANopen Lift 417 with dedicated SW.



SAFETY FUNCTIONS

Safety features to prevent accidental motor start:

- > SBT Safe Brake Test
- > EBC Electronic Brake Control SIL3^(*)
- > STO Contactless SIL3 (Category PLe).

(*) with external accessory module (in preparation)



Modbus TCP



CANopen

OPTIONAL PROGRAMMING KEYPAD

The optional programming keypad is easy to use and always ready.

INTEGRATED KEYPAD

The built-in programming keypad enables quick and easy drive setup.

INPUT / OUTPUT

| | |
|--------------------|------------|
| Analog input | 2 |
| Digital input | 8-1 Enable |
| Digital output | 4 (Relays) |
| Fast digital input | 2 |

UNIVERSAL INTEGRATED MULTI-ENCODER

Selects the encoder type from the parameter without adding dedicated boards, such as: SinCos, Endat, Biss, Digital Incremental.

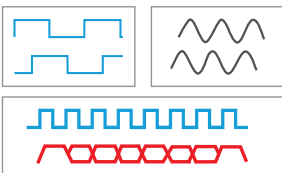

SAFETY FUNCTIONS

Safety features to prevent accidental motor start:

- > SBT Safe Brake Test
- > EBC Electronic Brake Control SIL3^(*)
- > STO Contactorless SIL3 (Category PLe).

^(*) with external accessory module (in preparation)



ETHERNET PORT

Built-in Ethernet communication with Modbus TCP protocol for direct/LAN connection to monitor and configure the drive or for remote gateway connection.



Modbus TCP

GREEN SOLUTIONS AND FEATURES

- > Regenerative configuration with the AFE200 external modules.
- > Reduced consumption thanks to system stand-by management logic combined with external +24Vdc power supply.
- > Hybrid power supply with super capacitors.
- > Indicator of system regeneration potential.



LIFT CONTROL CARD

Card integrated to control Lift functions: safety chain, 6 relay outputs and 16 digital inputs.

USB PORT

- > Uploading and downloading parameters file.
- > Motor selection and upload of data plate information from database.
- > Uploading languages and SW applications on board the drive.



Wi-Fi COMMUNICATION

Plug-in for optional Drive Link Wi-Fi module for wireless communication via GF_Liftouch APP.



CANopen



Taylor Lifts offer a range of high quality Wire Wound Dynamic Braking Resistors to suit all VVVF Invertors.

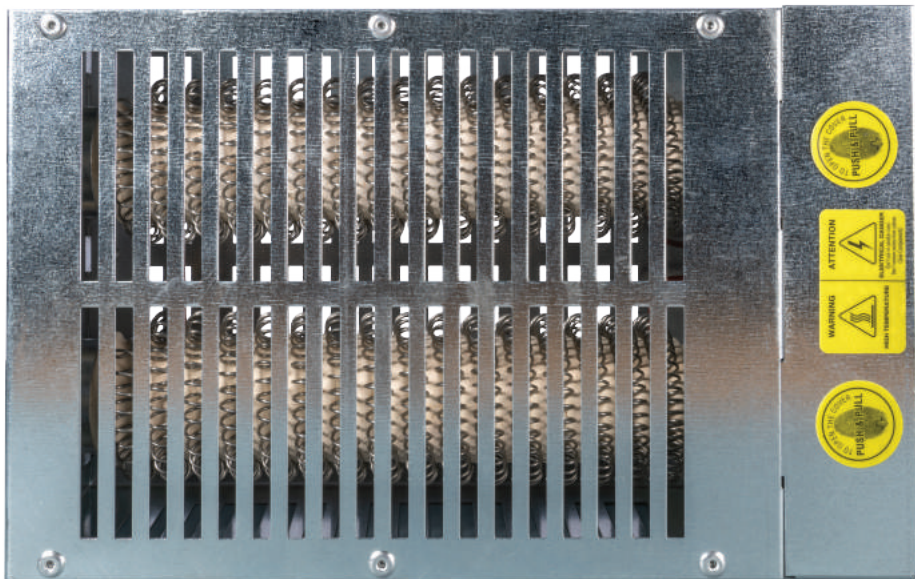

Technical Specifications:

Cooling: Natural Convection

Electrical Terminal: Porcelain Terminal

Mounting Position: Horizontal

Resistance Values (Ohms for 20 C): 10 Ohms - 120 Ohms

Resistance Tolerance (for 20 C): 5%



Taylor Lifts offer this product as part of a new Hydraulic control panel or as a supply or supply and fit option to an existing control panel.

This Soft Starter is a device used to reduce the starting current and the power engaged by 3-phase asynchronous motors.

- The device will drastically reduce the transient currents generated during Star/Delta changeover and allow smooth acceleration current, reducing mechanical stress on the machine thus prolonging its life.
- Can be easily installed with any kind of lift, new or existing, connected into either direct-on-line or Star/Delta configuration.
- It is characterised by the reduced size, the EMC filter, and an easier installation.
- Complies with EN81 series of regulations and is EMC Certified by a Competent Body.

SPECIFICATIONS

Power supply: 220, 400, 415 Vac 3-phase (50-60 Hz)

SSV040

- 40A Rated current direct online
- 65A Rated current on delta

SSV070

- 70A Rated current direct online
- 115A Rated current on delta



SSW105

- 105A Rated current direct online
- 168A Rated current on delta

SSW160

- 160A Rated current direct online
- 56A Rated current on delta

Takedo-Energy is a kit able to recover braking energy of lifts regulated by inverters. When the motor is pulled by the load, it generates energy. Takedo-Energy takes this energy and returns it to the A.C. line. The regenerated energy can be used by all the other users connected to the same meter.

- Extremely easy to install: only 7 wires to connect.
- Recovers into the mains the braking energy normally dissipated by the braking resistor.
- Ensures maximum energy saving and at the same time reduces the heating in the machine room.
- Suitable also for escalator

This replaces the existing dynamic braking resistor. The benefit of this is the regeneration of wasted energy from a heavy counterweight travelling downwards or a full loaded lift car travelling down. The energy from the motor is returned to the mains instead of being burnt off in the Dynamic braking resistors.



Taylor Lifts offer a range of digital encoders.

The base product range is as follows:-

- Small through hole hollow shaft up to 15mm
- Large through hole hollow shaft up to 44mm
- Shafted 6mm
- Adaptor shaft to give plain shaft size, as required
- Adaptor shaft to give threaded shaft, as required
- Mounting brackets made to suit site requirements
- Stock encoders 1024ppr/5-30VDC HTL
- Full range of encoders can be supplied by special order
- Absolute encoders for gearless machines, SIN COS/EnDAT





Hall Effect Sensors



Reed Switch Sensors



Bistable Sensors



Limit Switches

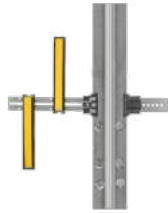

Magnets



Fixing Kits

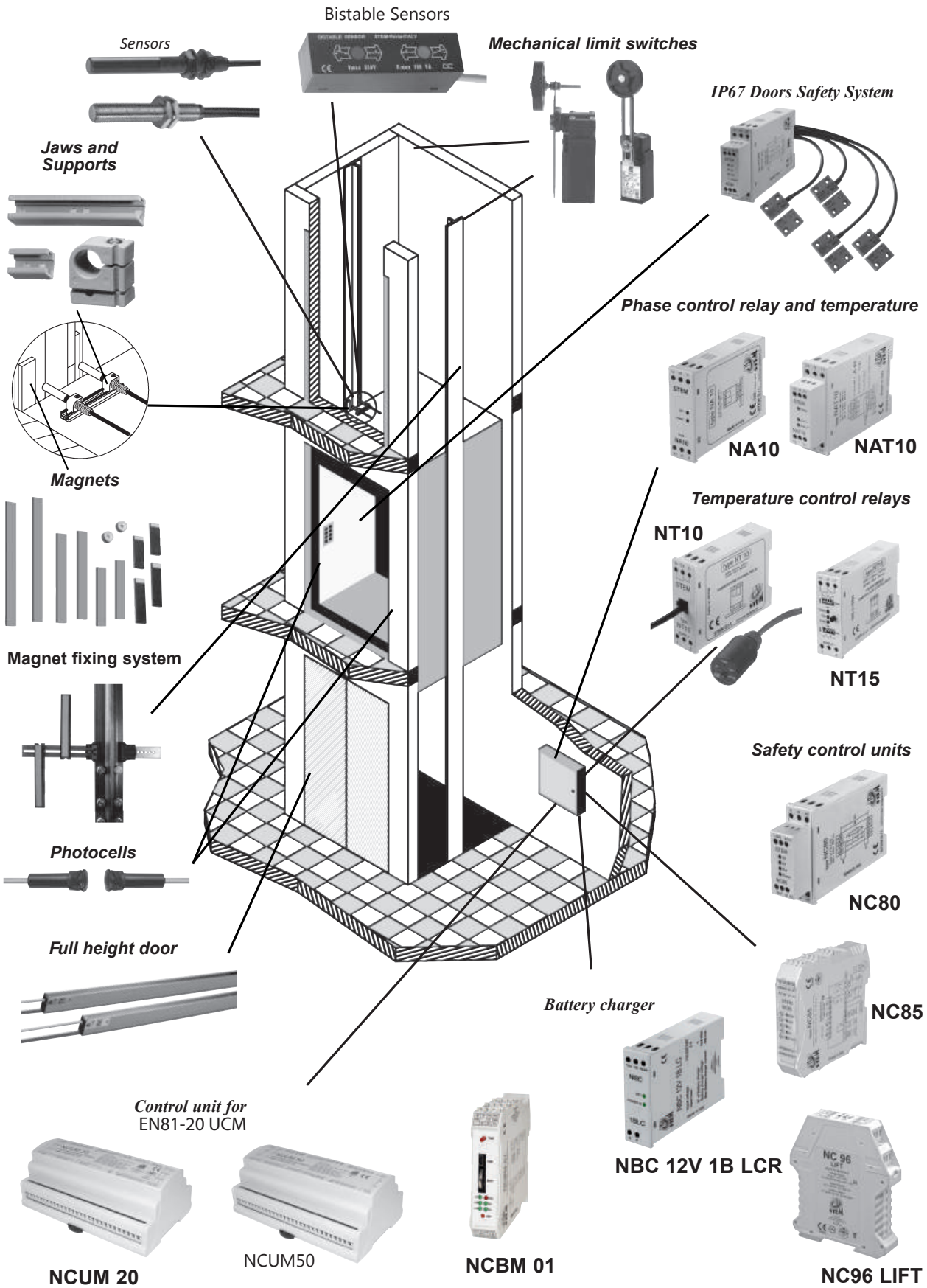



Half-threaded M12x1 Hall Effect sensor
Non-flammable nylon glass body sensor C12H

Threaded M12x1 Hall Effect sensor
Non-flammable nylon glass body sensor C19H

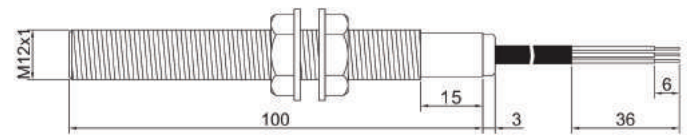
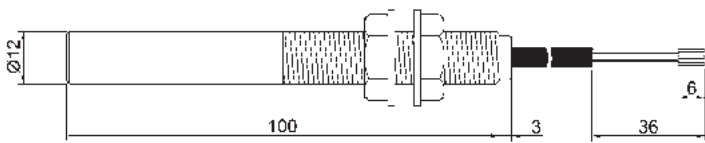
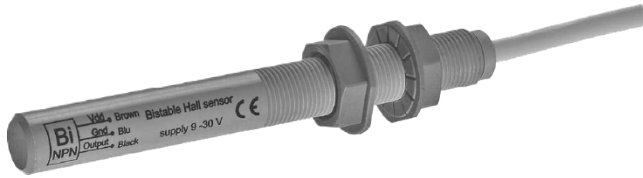

| Connection Scheme | Body | | Contact | | | | Cable | | | | |
|---------------------|--------------|--------|-----------------|---------|-----|--------------|---------------|-------|-------------|----------------------------|----------------|
| | Series | Colour | Contact | Voltage | | Power VA max | Current A max | Cable | Diameter mm | Conductors mm ² | Features |
| | | | | Vdc | Vac | | | | | | |
| NO | C121 C191 | black | 1A ¹ | 100 | 150 | 10 | 0,5 | DA | 5 | 0,5 | black bipolar |
| | | | 1F ¹ | 200 | 250 | 50 | 1 | | | | |
| | | | 1L ¹ | 250 | 250 | 100 | 3 | | | | |
| NC | C123 C193 | black | 1M | 150 | 150 | 10 | 0,5 | DA | 5 | 0,5 | black bipolar |
| | | | 1N ¹ | 220 | 220 | 60 | 1 | | | | |
| | | | 1P* | 250 | 250 | 100 | 3 | | | | |
| EX | C125 C195 | black | 1T ¹ | 220 | 220 | 60 | 1 | TE | 5 | 0,5 | black tripolar |
| BISTABLE | C127 C197 | grey | BC ¹ | 250 | 250 | 100 | 3 | BF | 5 | 0,5 | grey bipolar |
| | | | BD ¹ | 230 | 230 | 60 | 3 | | | | |
| | | | BG | 200 | 250 | 50 | 1 | | | | |

| HOMOLOGATED Connection scheme | Body | | Contact | | | | Cable | | | | |
|----------------------------------|------------------------------|--------|---------|---------|-----|--------------|---------------|-------|-------------|----------------------------|---------------|
| | Series | Colour | Contact | Voltage | | Power VA max | Current A max | Cable | Diameter mm | Conductors mm ² | Features |
| | | | | Vdc | Vac | | | | | | |
| NO | C121 C191 C122 C192 | black | 1V | 250 | 250 | 10 | 0,04 | DA | 5 | 0,5 | black bipolar |
| | | | 1L | 250 | 250 | 100 | 0,4 | | | | |
| BISTABLE | C12G | grey | B3 | 220 | 220 | 100 | 0,4 | BF | 5 | 0,5 | grey bipolar |

Order code example C121 1A DA 0 140

SERIES _____

CONTACT TYPE _____

CABLE TYPE _____

SPECIAL FEATURES _____

LENGTH IN cm _____

Technical features

| | |
|-------------------------|------------------|
| Mechanical life | 100.000.000 |
| Operation frequency | 250 imp/sec |
| Repeatability precision | 0,1 mm |
| Impact resistance | 30 g/11 ms |
| Vibration resistance | 0,35 mm 10-55 Hz |
| Working temperature | -20° +90° C |

Half-threaded magnetic sensor M12x1
Non-flammable nylon glass body sensor **C12**

Full-threaded magnetic sensor M12x1
Non-flammable nylon glass body sensor **C19**

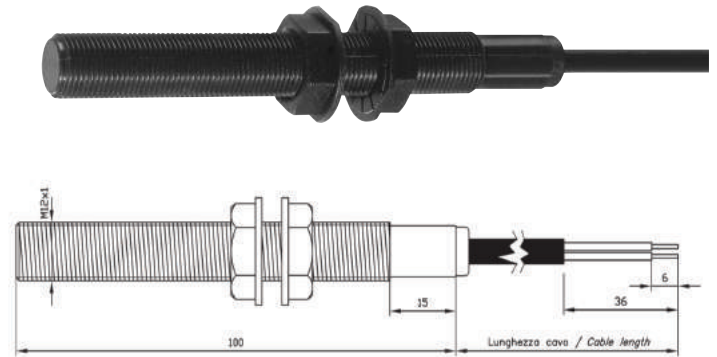
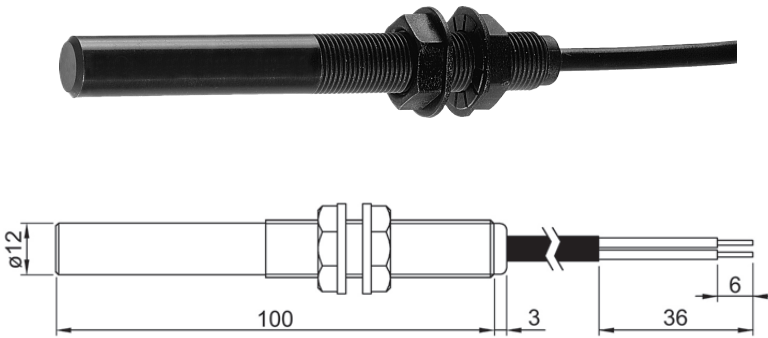

| Connection Scheme | Body | | Contact | | | | | Cable | | | |
|---------------------|--------------|--------|-----------------|---------|-----|--------------|---------------|-------|-------------|----------------------------|----------------|
| | Series | Colour | Contact | Voltage | | Power VA max | Current A max | Cable | Diameter mm | Conductors mm ² | Features |
| | | | | Vdc | Vac | | | | | | |
| NO | C121 C191 | black | 1A ¹ | 100 | 150 | 10 | 0,5 | DA | 5 | 0,5 | black bipolar |
| | | | 1F ¹ | 200 | 250 | 50 | 1 | | | | |
| | | | 1L ¹ | 250 | 250 | 100 | 3 | | | | |
| NC | C123 C193 | black | 1M | 150 | 150 | 10 | 0,5 | DA | 5 | 0,5 | black bipolar |
| | | | 1N ¹ | 220 | 220 | 60 | 1 | | | | |
| | | | 1P* | 250 | 250 | 100 | 3 | | | | |
| EX | C125 C195 | black | 1T ¹ | 220 | 220 | 60 | 1 | TE | 5 | 0,5 | black tripolar |
| BISTABLE | C127 C197 | grey | BC ¹ | 250 | 250 | 100 | 3 | BF | 5 | 0,5 | grey bipolar |
| | | | BD ¹ | 230 | 230 | 60 | 3 | | | | |
| | | | BG | 200 | 250 | 50 | 1 | | | | |

| HOMOLOGATED Connection scheme | Body | | Contact | | | | | Cable | | | |
|----------------------------------|--------------|--------|---------|---------|-----|--------------|---------------|-------|-------------|----------------------------|---------------|
| | Series | Colour | Contact | Voltage | | Power VA max | Current A max | Cable | Diameter mm | Conductors mm ² | Features |
| | | | | Vdc | Vac | | | | | | |
| NO | C121 C191 | black | 1V | 250 | 250 | 10 | 0,04 | DA | 5 | 0,5 | black bipolar |
| | | | 1L | 250 | 250 | 100 | 0,4 | | | | |
| BISTABLE | C12G | grey | B3 | 220 | 220 | 100 | 0,4 | BF | 5 | 0,5 | grey bipolar |

Order code example: C121 1A DA 0 140

SERIES: _____

CONTACT TYPE: _____

CABLE TYPE: _____

SPECIAL FEATURES: _____

LENGHT IN cm: _____

Technical features

| | |
|-------------------------|------------------|
| Mechanical life | 100.000.000 |
| Operation frequency | 250 imp/sec |
| Repeatability precision | 0,1 mm |
| Impact resistance | 30 g/11 ms |
| Vibration resistance | 0,35 mm 10-55 Hz |
| Working temperature | -20° +90° C |

Rectangular bistable magnetic sensor Non-flammable nylon glass body sensor

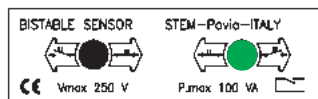
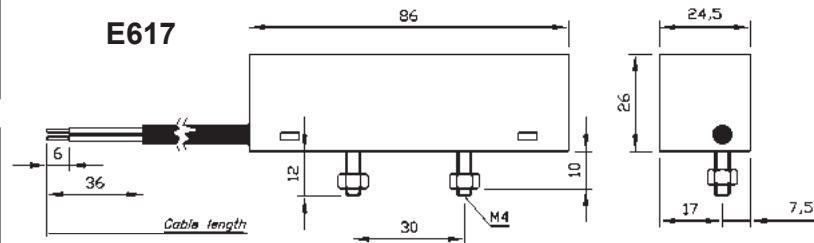
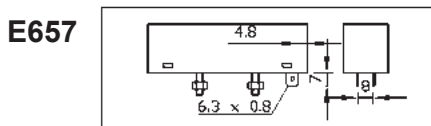
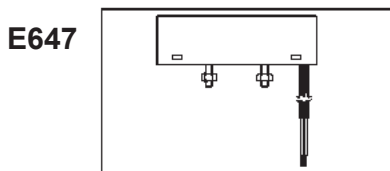
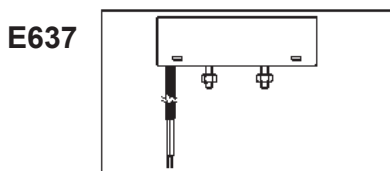
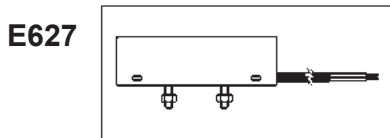
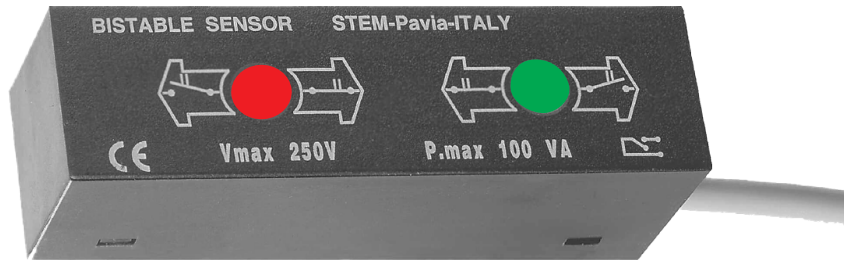

Technical features

| | |
|-------------------------|------------------|
| Mechanical life | 100.000.000 |
| Operation frequency | 250 imp/sec |
| Repeatability precision | 0,1 mm |
| Impact resistance | 30 g/11 ms |
| Vibration resistance | 0,35 mm 10-55 Hz |
| Working temperature | -20° +90° C |

| Connection scheme | Body | | Contact | | | | Cavo / Cable | | | | |
|-------------------|--------|--------|---------|---------|-----|--------------|---------------|-------|-------------|----------------------------|--------------|
| | Series | Colour | Contact | Voltage | | Power VA max | Current A max | Cable | Diameter mm | Conductors mm ² | Features |
| | | | | Vdc | Vac | | | | | | |
| | E617 | black | BC | 250 | 250 | 100 | 3 max | CA | 5 | 0,5 | grey bipolar |
| | E627 | | | | | | | | | | |
| | E637 | | | | | | | | | | |
| | E647 | | | | | | | | | | |
| | E657 | black | BC | 250 | 250 | 100 | 3 max | 00 | - | - | - |

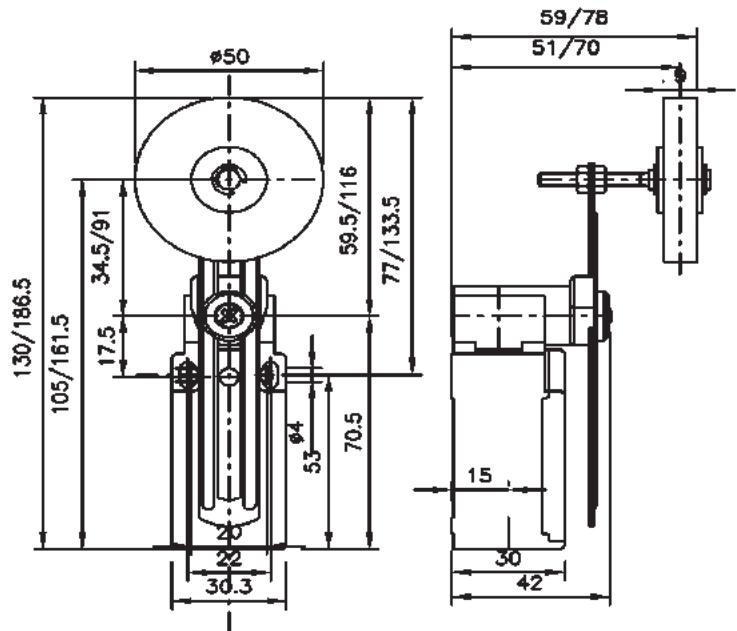

The STEM mechanical limit switches, series AP1T, are doubled insulated, and housed in reinforced fiberglass material. The limit switch is fully adjustable and have a mechanical snap action. The cable entry is in the base and is suitable for a PG13.5 cable gland. All the mechanical limit switches have a mechanical snap action.

Contact with snap action 1 N.O. + 1 N.C.

Technical data:

Technical of use: AC15 / DC13 (A600, Q600)
 Rated thermal current: I_{th} 10A
 Operating temperature range: -25 °C , +70 °C
 Protection degree: IP65

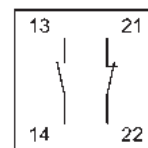

Standards:

Conformity to the directive:
 73/23/CEE mod. by 93/68/CEE (B.T.)89/392/CEE (Machinery)
 is declared with ref. to the standards:
 CEI EN 60947-5-1
 UL 508
 EN 1088
 CSA C22-2
 n.14
 CEI EN 60204-1



The most commonly used magnet in the lift market are made from plastroferrite. Dimensions have a direct effect on the strength and activation distance of the magnets. Wider, thicker or longer magnets will have a higher magnetic flux. Length will only effect the strength of the magnet up until a certain point, where as width and thickness will continually effect magnetic flux.

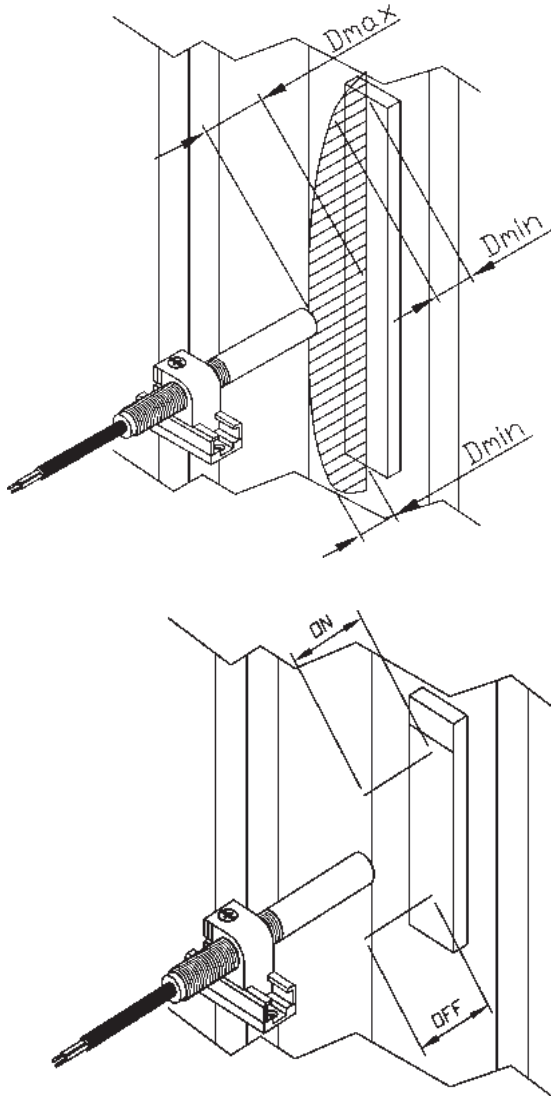

| CONTACT | | 150 x 15 x 6 mm | | 150 x 20 x 6 mm | |
|---------|------------|-----------------|------|-----------------|------|
| | | Dmin | Dmax | Dmin | Dmax |
| NO | 1L (100 w) | 10 | 20 | 15 | 33 |

As seen in the table, a magnet with a 5mm increase in width, considerably increases the activation distance.

| CONTACT | | 150 x 15 x 6 mm | | 150 x 15 x 8 mm | |
|---------|------------|-----------------|------|-----------------|------|
| | | Dmin | Dmax | Dmin | Dmax |
| NO | 1L (100 w) | 10 | 20 | 14 | 26 |

The activation distance also increases when the plastroferrite thickness is increased.

| CONTACT | | 150 x 15 x 6 mm | | 200 x 15 x 6 mm | |
|---------|------------|-----------------|------|-----------------|------|
| | | Dmin | Dmax | Dmin | Dmax |
| NO | 1L (100 w) | 10 | 20 | 12 | 22 |

Magnets can be supplied in a variety of sizes, however standardisation in the lift market has led to the use of magnets with little variety of sizes.

The most commonly used plastroferrite is 150 mm long, 15 mm wide and 6 mm thick. On the base of the results shown in the charts, a magnet with a width of 20 mm is recommended to give more magnetic flux and therefore greater activation distances.

Plastroferrite can also be used for bistable sensors. Magnets with a width of 20mm and length of 80mm are most commonly used. Activation distances can be increased by doubling the thickness of the magnet.

| CONTACT | | 80 x 20 x 6 mm | | 80 x 20 x 12 mm | |
|---------|------------|----------------|------|-----------------|------|
| | | Dmin | Dmax | Dmin | Dmax |
| Bi | BC (100 w) | 20 | 20 | 25 | 25 |
| Bi | BD (60 w) | 30 | 30 | 35 | 35 |

Monostable Magnets

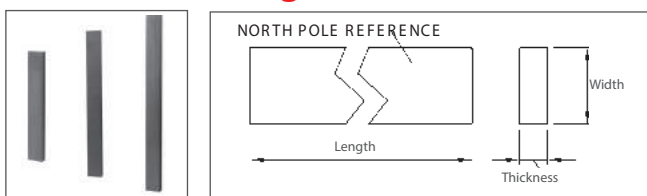

| CODE | LENGTH | WIDTH | THICKNESS |
|-----------------|--------|-------|-----------|
| MP P100 015 006 | 100 | 15 | 6 |
| MP P150 015 006 | 150 | 15 | 6 |
| MP P200 015 006 | 200 | 15 | 6 |

Bistable Magnets

SOUTH POLE PAINTED IN WHITE COLOUR

ON

OFF

| CODE | LENGHT | WIDTH | THICKNESS |
|-----------------|--------|-------|-----------|
| MP D060 020 006 | 60 | 20 | 6 |
| MP D080 020 006 | 80 | 20 | 6 |

Plastoferrite is normally used when a signal needs to be recieved for a certain length of time ie. floor presence signalling. If instead the signal needs to be recieved at specific points of the lift rail (ie for acceleration or deceleration in proximity of floors) then magnets made from different materials can be used (ferrite/neodym). These can both be used for monostable and bistable sensors. These magnets have higher magnetic flux, therefore if they have the same dimensions, activation distances can be higher or lower. If the distance is the same, magnets with smaller dimensions can be used.

| | | |
|---|--|---|
| <p>Ferrite</p> <p>CODE</p> <p>MFA 020 004 010</p> | <p>Ferrite</p> <p>CODE</p> <p>MFA Z23 Z04 010</p> | <p>Ferrite</p> <p>CODE</p> <p>MFDIAM 028 005</p> |
| <p>Neodym</p> <p>CODE</p> <p>MNDIAM 020 003</p> | <p>Neodym</p> <p>CODE</p> <p>MNDIAM 018 003</p> | <p>Ferrite</p> <p>CODE</p> <p>M613 F CGB A000</p> |
| <p>Neodym</p> <p>CODE</p> | <p>Neodym</p> <p>CODE</p> <p>neodym magnet diam 18x5</p> | <p>Ferrite</p> <p>CODE</p> <p>MFP 020 014 012</p> |
| <p>Ferrite</p> <p>CODE</p> | <p>Ferrite</p> <p>CODE</p> | <p>Ferrite</p> <p>CODE</p> |

STEM manufacture a range of fixing kits, which make it possible to fit sensors to the roof of lift cars, as well as fixing magnets to lift rails. This patented system provides a simple, easy and inexpensive solution, and only requires a couple of STEM products. The below fixing kit is used to fix sensors to a car roof.

Unistrut Jaw

Length 150mm, Code 112003 000 000



The Unistrut Jaw is designed with slots to fit the Sensor holder (below) into place. The Jaw is then fitted easily onto the lift car roof, either screwed into place or glued. Taylor Lifts supply a length of 150mm, which can be shortened using the grooves on the reverse of the jaw.

Patented Sensor



The Sensor Holder, is used to hold the sensor in place, using the screw head. Once happy with the positioning of the sensor, the screw can be tightened. The slots on the Sensor Holder make it easy to slide into position on the jaw.

The sensor holder can also be used to fit two jaws together perpendicularly, in order to fit sensors in a vertical position, using the slots on both the jaw and holder.

E Sensor Support

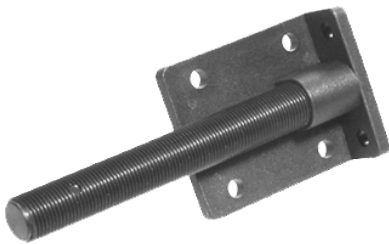

The E617 Sensor holder is used to fix the E6*7 sensors into place on a lift car roof. Using the Unistrut Jaw, and Sensor Holder. The E Sensor Support fits easily into the sensor holder, and the Sensor attaches to the head using 4 screws.

Fixing Example:

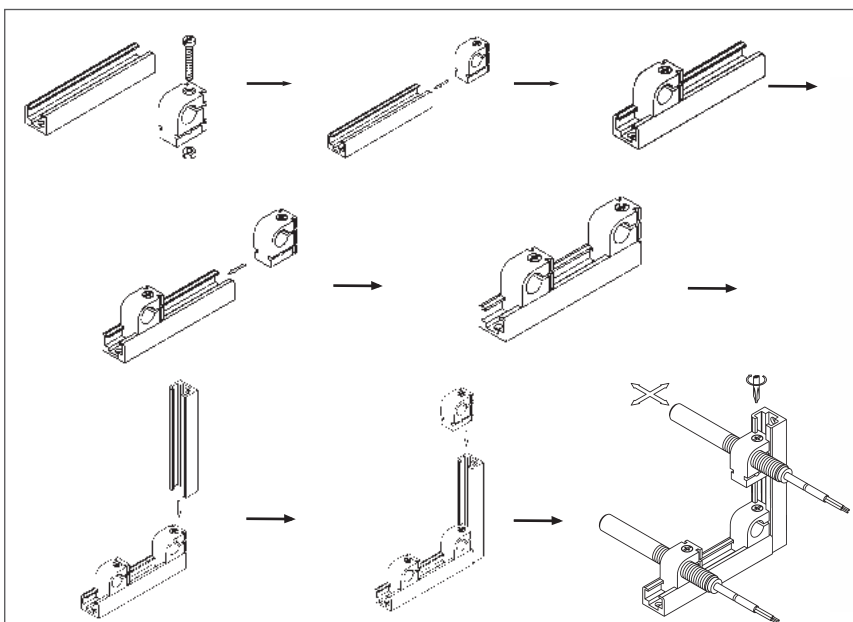

The STEM fixing system: the KITFX, KITPM and KITEX, make it possible to fix magnets to lift rails, in a cost effective and simple way. The system is adaptable to any type of lift rail, and can also be used to fit limit switches.

RAIL FIXING KIT

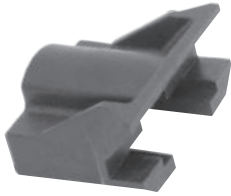

Left jaw (Moveable)

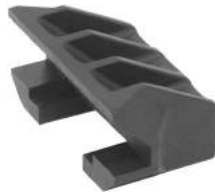

Right jaw (Fixed)



Support plate

The KITFX is the first step to attach magnets to lift rails. The plate is locked onto the right fixed jaw, using supplied screws, and then attached to the lift rail. The left jaw will then slide onto the support plate to fix the KITFX into place. The shape of the jaws are designed to create a strong grip on the lift rail regardless of shape or size of rail.

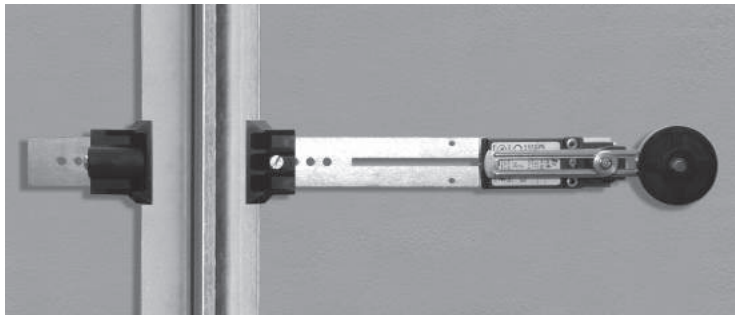

As seen in the image (left) Limit Switches can be fitted to the end of the support plate. Mounting is simple, this fixing kit is compatible with most Limit Switches.

EXTENSION KITS



The KITEX is used to extend the length of KITPM (next page) to fit a longer magnet. It is easily screwed in place to join two KITPM's together.

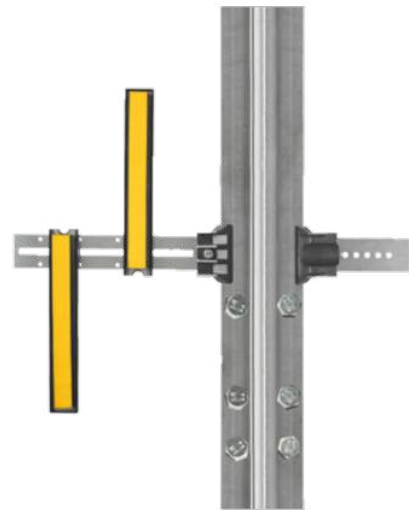

MAGNET HOLDER KITS

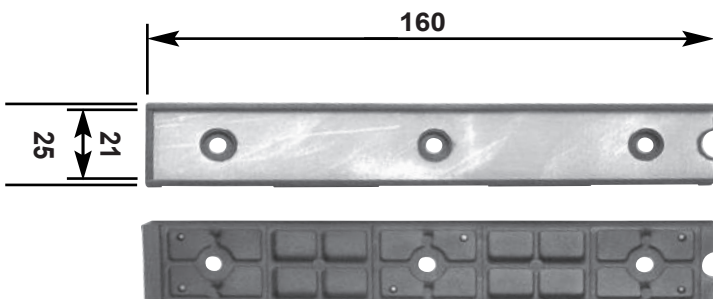

The KITPM (magnet holder) is easily fitted to the KITFX using the screws provided. It can be fitted at three different heights, using the shown holes. The plate is magnetic, therefore the magnet can simply be placed upon it once the PM is fixed into place.

As well as being fixed at multiple heights, multiple KITPM's can also be fitted to the KITFX.



Displays



Buttons



Fixtures

Taylor Lifts supply a range of LCD or TFT displays, available in different sizes with configuration via PC or windows.



IRIS 2.8"

High resolution landing position indicator

- Easy configuration via PC.
- Update by SD Card.
- Customizable background, arrows, floors and signalling.
- UNI EN 81-70.
- Energy saving system mode (stand-by).
- Easy keypad for the selection of the main features (buzzer volume, communication interface, first floor, brightness, stand-by duration).
- Courtesy light.
- Communication interface: Vega serial, RS485, CAN, parallel and magnetic sensors.
- Mounting: protection case.
- Mounting: horizontal and vertical



IRIS 4.3"

High resolution landing and car position indicator

- Easy configuration via PC.
- Updating by SD Card.
- Customizable background, arrows, floors, logo and signalling.
- UNI EN 81-70.
- Customizable background with pictures and sounds (for car position indicators).
- Energy saving system mode (stand-by).
- Easy keypad for the selection of the main features (buzzer volume, communication interface, first floor, brightness, stand-by duration).
- Integrated emergency light.
- Communication interface: Vega serial, RS485, CAN, parallel and magnetic sensors.
- Mounting: protection case.
- Mounting: horizontal and vertical.
- Calendar and temperature.
- Software updating is available by USB port on a button in the car.



IRIS 5.7"

Car tft position indicator

- Easy configuration via PC.
- Updating by SD Card.
- Customizable background, arrows, floors, logo and signalling.
- UNI EN 81-70.
- Customizable background with pictures and sounds
- Energy saving system mode (stand-by).
- Easy keypad for the selection of the main features (buzzer volume, communication interface, first floor, brightness, stand-by duration).
- Integrated emergency light.
- Communication interface: Vega serial, RS485, CAN, parallel and magnetic sensors.
- Mounting: horizontal and vertical.
- Calendar and temperature.
- Voice synthesizer on board



ICARO

Landing lcd position indicator.

- Lcd model: indicator lcd available in blue or black background.
- Fast Fixing: frontal mounting with frame or flush mounting on 1.2 and 2mm faceplates through soldered studs.
- Screen: lens polycarbonate (shock-proof and anti-crash).
- Colours: white LED on blue background or 5 different colours (navy blue, white, yellow, green and red) on black background.
- Wiring: screws or pre-wired connectors (AMP or JST).
- Common: positive or negative.
- Power supply: 12/24Vdc +/- 10%.
- Signals: floors, arrows, out of service.
- Optional signals: sent alarm and overload signal.
- Integrated and programmable three-tone chime.
- Easy programming by a dedicated integrated keyboard.
- 32 stops in binary code, 11 stops 1 wire for floor.
- 64 stops in independent mode (magnetic sensors).
- Up and down arrow (40,5mm).
- Available in CAN and RS485 serial version.
- Possibility to implement binary, inverted binary, BCD, Gray and 7 segments codes.



SNV201-ENC

Encoder board with integrated speech synthesizer.

- Encoder board for transforming discrete wiring signals (one wire per floor, binary, gray, etc.) into a proprietary RS485 serial communication protocol Integrated speech synthesizer.
- Stand-alone mode, by using magnetic sensors and magnets.
- Channel for external speaker 4-8 1, 1-5W.
- Dual language announcements.
- Audio programming menu.
- Audio and visual (by the connected displays) programming menu

Dimensions

103x72x25 mm



Achille Range Push Button

- Body: zamak and nylon push button.
- Bezels: zama (chrome or gold, pearled nickel, pearled gold, anthracite).
- Pressel: polycarbonate with stainless steel AISI 304 or gold/black pvd coated finishes; raised legend(s) and Braille.
- Mounting: the button is put into the cutout (Ø 32,2) from the front and fixed by threaded ring.
- Faceplate Thickness: 0,7 mm to 5 mm.
- Contacts: 1 micro switch or 2 micro switches.
- Wiring: PIN or pre-wired connectors (AMP, JST or minispox).
- Illumination: Led 12V o 24V DC 30mA.
- Stroke: 1,2 mm.
- Avg. life: 2.000.000 activations.
- Degree of protection: IP51 with metal spring/IP54 with silicone spring and o-ring.

Lighting: Red, Green, Blue, White

Achile Bicolour: Red/Blue, Blue/Red, White/Blue, Blue/White, White/Red



Ulisse Range Push Button

- Body: polycarbonate pushbutton with raised symbol (EN 81-70 norm).
- Bezels: metallized ABS in gold or chrome.
- Mounting: quick fastening on 0.7mm to 5mm faceplates. 1° STEP: body's push buttons by jam-nut and 2° STEP, automatic mounting of circuit's case.
- Pressel: polycarbonate with stainless steel AISI 304 or gold pvd coated finishes; tactile (raised) and illuminated legend(s).
- Contacts: 1 micro switch o 2 micro switches.
- Wiring: PIN connectors.
- Illumination: Led 12V o 24V DC 20mA.
- Stroke: 1,2 mm.
- Avg. Life: 2000000 activations.
- Degree of protection: IP51.

Lighting: Red, Blue, Green, White



Venus Push Button

- Body: nylon push button.
- Bezels: stainless steel (Ø 38,2mm).
- Pressel: polycarbonate with stainless steel AISI 304 or gold/black pvd coated finishes; illuminable raised legend(s) and Braille.
- Mounting: the button is put into the cutout (Ø 32,2) from the front and fixed by threaded ring.
- Faceplate Thickness: 0,7 mm to 5 mm.
- Contacts: 1 micro switch o 2 micro switches.
- Wiring: PIN or pre-wired connectors (AMP, JST or minispox).
- Illumination: Led 12V o 24V DC 30mA.
- Stroke: 1,2 mm.
- Avg. life: 2.000.000 activations.
- Degree of protection: IP51.

Lighting: Red, Blue, Green, White

Bicolour: Red/Blue, Blue/Red, Red/Green, White/Blue, Blue/White, Red/White



Giunone

- Body: zamak push button (body and bezel united).
- Rules: UNI EN 81-70 standards, CLASS 1.
- Pressel: polycarbonate with stainless steel AISI 304 or gold/black pvd coated finishes; raised legend(s) and Braille.
- Mounting: the button is put into the cutout from the front and fixed by threaded ring.
- Faceplate Thickness: 0,7 mm to 5 mm.
- Contacts: 1 micro switch o 2 micro switches.
- Wiring: PIN or pre-wired connectors (AMP, JST or minispox).
- Illumination: Led 12V o 24V DC 30mA.
- Stroke: 1,2 mm.
- Avg. life: 2.000.000 activations.
- Bicolor in red, blue, green and white.
- Finishes: blasted stainless steel, gold bead blasted, black bead blasted

Dimensions: 54.2mm*54.2mm



I-Button

- Safety: I-Button system guarantees keys that can not be reproduced.
- Mounting: easy replacement for modernizations thanks to the dimensions suitable with all Vega push buttons.
- Resistance: vandal resistant body with not magnetic key.
- Easy setting: Easy programming for MASTER and SERVICE key.
- Up to 500 programmable keys.
- Backup management to save and transfer key(s) codes.
- Available versions: monostable, bistable or automatic push buttons.
- Degree of protection: IP51.



Keyswitch

- Body: Key block integrated in polycarbonate body with illuminated halo.
- Bezel: metallized ABS (gold or chrome); it is available in the ROUND and SQUARE version.
- Front part: Stainless Steel ring and key block.
- Mounting: it is put into the 32,2 cutout from the front and fixed by threaded ring.
- Faceplate thickness: 0,7 to 3mm.
- Wiring: by wires.
- Halo voltage: (4XLED) 12 or 24 VDC I=20mA.
- Degree of protection: IP51.
- Optional: key block for VENUS XL model

Available in:

- 2 position/1 extraction
- 2 positions/2 extractions
- Spring return

Buttons & Displays | Fixtures

Taylor Lifts offer a range of quality UK custom made Stainless Steel car operating stations, Landing push stations, and Digital indicator enclosures. All units offer vandal resistant secure fixings.

The base product range is as follows:

- Surface Mount
- 2mm 304g Brushed finish stainless steel
- Vandal Resist Fixings

Surface Mount COP



Surface Mount LOP



Flatplate Display



Surface Mount LOP



Angled Display Box





Control Gear



Cable



Terminal Boxes



Car Top Control



Autodialers



Detector Edge



Air Purifier

Lift Components | Control Gear

Taylor Lifts can supply an extensive range of replacement parts for most lift control systems.

We currently stock a wide range from:

OMRON

Power supplies, Relays, Timers

For more details please enquire: sales@taylorlifts.co.uk

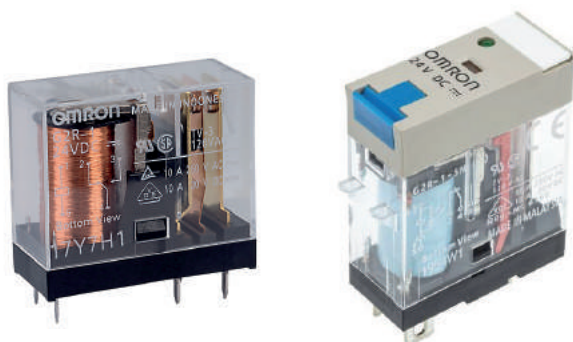

Schneider Electric

Relays, Contactors, Timers, Circuit Breakers

For more details please enquire: sales@taylorlifts.co.uk



GEFRAN

Inverters, see pages 20-24



Proximity Sensors,
Control Units, Safety Relays

Taylor Lifts stock a range of multicore cable, 0.75mm & 1mm.
Available in 5, 7, 12, 18, 24 core

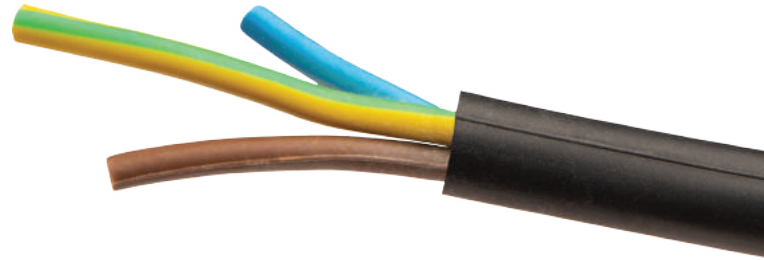

Ölflex® Classic 110 YY Cable

From Lapp, the Ölflex Classic 110 YY Cable is a robust cable designed for use under medium mechanical stresses, such as power chain applications. The cable is suitable for fixed installation purposes, as well as those that require occasional flexing and movement.

This YY control cable consists of fine wire copper strands, with a special PVC conductor insulation and sheathing that is suitable for use in both dry and humid conditions. The cable also has a good resistance to chemicals and oils, making it ideal for challenging industrial environments.

YY cable is an excellent control cable solution for a variety of applications.

For more information please enquire: sales@taylorlifts.co.uk

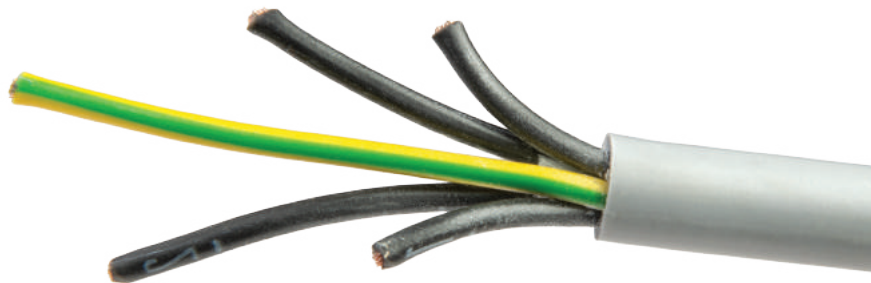

Lift Components | Terminal Boxes

Taylor Lifts can supply Car Top and Shaft Terminal boxes fitted with cage clamp terminals. Standard boxes have 50 terminals, other variations available on request.

Standard box size is 130mm high x 300mm wide x 200mm deep and a finished in high quality powder coated grey.



Taylor Lifts Car Top Control, manufactured in house by qualified engineers

- EN81-20/50 Compliant
- BS7255 Compliant
- Switched RCD Socket for Small Hand Tools
- Emergency Stop Button with Flag Indication
- Shrouded Inspection/Normal Control
- Shrouded Door Open/Close Switch
- Colour Coded Buttons and Background
- UP/DN & Common Buttons
- Engineers Alarm Button (for Linking to Autodialler)
- Led Lamp on Wander Lead with Magnetic Attachment
- Compact Steel Construction
- Options for Pre-Wired and 12V Battery Backed up Supply
- Option for terminal rail



Safeline is a Swedish company that manufactures safety accessories for lifts. They have over 250 000 installed lift telephones which makes them the largest independent manufacturer specialising in lift safety products in Europe.

They produce good quality products that are simple to install and easy to configure. Products are tailored for the lift industry.



Safeline MX3+

Small size – great flexibility

The MX3+ is possibly the world’s smallest lift emergency telephone on the market today, but do not let small size fool you – there has been no compromise in neither function nor quality.

With CONNECT-compatibility, connection of external pictograms, extra voice station and more, the MX3+ is simply the ideal solution for machine room-less lifts or projects where physical space is otherwise limited.



Safeline SL6

SafeLine SL6 – The complete lift emergency telephone and fire communication system in accordance with EN81-28, EN81-70 and EN81-72.

Digicom is an Italian company, they have developed a complete suite of solutions operating with 4G/5G, ranging from connectivity to integration with cloud systems.



GSM Gateway

The 3G Lift has one FxS analog port to connect to any remote alarm system. The analog port simulates a PSTM - Telecom line using the GSM network instead of a wired line, which provides an effective cost saving solution.

Features:

- Universal 3G GSM GPRS communicator
- Suitable to all phone alarm systems
- Penta-band module
- Integrated battery back-up
- EN81-28 compliant
- Roaming block management



PSTN Lift Dialer

PSTN Lift Dialer is a remote alarm system designed to ease the installation by requiring 2 wires for voice, data and signalling. Suitable for new instalations, as well as modernisations, in conjunction with the DIGICOM VoiceBOX it fits inside electrical panels by simply fixing onto the DIN rail. EN81-28 Compliant



VoiceBOX & VoiceBOX Car

VoiceBox is an innovative speakerphone device for remote alarm systems inside lifts. It is versatile, easy and quick to install in the car behind the control panel, it allows activation of the remote alarm system and establishes bi-directional audio communications to the service centre or engine room.

Installation is simple, which requires 2 wires coming from the 2G Dialer or PSTN Dialer, which is where the device draws its power from.

Features:

- EN81-28 & EN81-70 Compliant
- Lift emergencies LEDs
- Integrated microphone and speaker
- Requires only 2 connection wires

Taylor Lifts stock a range of Vega Detector Edges, also available with power supply units. More models available on request.



B-Lift Slim 12/24V

- Size (width x depth x height) 7x30x2000mm
- Detecting Height 20mm to 1850mm
- Number of IR diodes 32
- Scan beams (distance > 400mm) 154 beams
- Scan beams (distance < 400mm) 94 beams
- Opening 0mm - 4000mm
- Light Immunity 100,000 LUX
- Operating Temperature -20°C ~ +65°C
- Buzzer After continuous detection for 15s
buzzer on (when BUZZER SWITCH=ON)
- Cable length 3 mt
- Vandalism detection 120 sec. , 1 diode
- Automasking function 1260mm – 1850mm
- Output Relay
- IP 54



B-Lift 100

- Size (width x depth x height) 10x28x2000mm
- Detecting Height 20mm to 1849mm
- Number of IR diodes 17
- Scan beams (distance > 400mm) 94 beams
- Scan beams (distance < 400mm) 33beams
- Opening 0mm - 4000mm
- Light Immunity 100,000 LUX
- Operating Temperature -20°C ~ +65°C
- Buzzer After continuous detection for 15s
buzzer on (when BUZZER SWITCH=ON)
- Cable length 4 mt
- Vandalism detection 60 sec. , 3 non-adjacent diodes
- IP 54



B-Lift 200 EVO

- Size (width x depth x height) 10x28x2000mm
- Detecting Height 20mm to 1872mm
- Number of IR diodes 40
- Scan beams (distance > 400mm) 194 beams
- Scan beams (distance < 400mm) 118beams
- Opening 0mm - 4000mm
- Light Immunity 100,000 LUX
- Operating Temperature -20°C ~ +65°C
- Buzzer After continuous detection for 15s
buzzer on (when BUZZER SWITCH=ON)
- Standard Output Relay
- Test Output Relay
- IP 54

The Safespace elevator range technology can remove up to 99.99% of airborne microbes in minutes.

Designed using the elevator expertise of Formula systems and the proficiency in infection control technology from AIRsteril.

The most advanced viral and bacterial control technology of its kind sanitizing both the air and surfaces within an elevator car.

Control harmful bacteria and viruses 24 hours a day, 365 days a year.

- Proven to kill airborne and surface viruses and bacteria
- Eliminate unpleasant odours
- Enhanced protection for both staff and visitors
- Fan driven for consistent performance
- Safe and suitable for use in enclosed areas of continuous occupation
- Single unit offers coverage of up to 18m³
- Maintenance only once per year
- Technology proven to reduce absenteeism

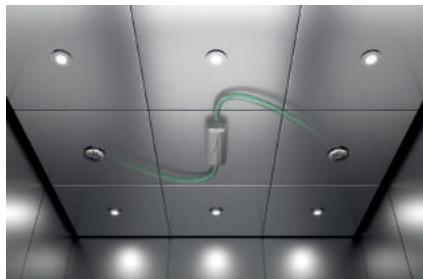

Image showing concealed unit above cab ceiling.



Only inlet and outlet vents visible from within cab

Unit Dimensions

410mm (L) x 130mm (W) x 95mm (D)

Power Supply

220-240V, 50-60Hz 17watts

Set Up

Unit concealed with only inlet and outlet vents visible in cab ceiling

Construction

Polycarbonate moulding

Weight

15kg

Operation

Continuous operation

Control Components



SMS Control Boards



NAT10



NT10



NT15



NBC12V



NC80 & IP67



NC85



NC96

NCUM20

NCUM50

NCBM01

Taylor Lifts stock the SMS Elesys Control Boards for rope, hydraulic and home lifts. SMS control boards are available in different configurations: APB, SIMPLEX MULTIPLEX, and DOWN COLLECTIVE up to 24 stops. They are a compact size, to suit MRL Panels, as well as rope, hydraulic and home lifts with any type of drive, and direct control via inverter.

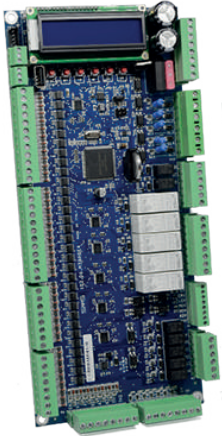

ELESYS is the new micro processor system manufactured by SMS for lifts control panel up to 32 stops for both down and full collective.

- Available in different configurations: APB to simplex multiplex and down collective up to 32 stops.
- Compact size suitable for installation in MRL control panels.
- For hydraulic, rope and home lifts, with any type of drive and direct control via inverter.
- Micro keyboard with built-in LCD display.



The **ELEXP** is an expansion board for the ELESYS System, a versatile and small size card. It is connected to the main boards (ELEMPU & ELEPLUS) via CANBUS and it can be used for the following applications:

- Expansion of car and landing calls, in order to manage the collective operation up to 32 stops.
- Decoder for car position signal with '7 segment' display
- Decoder for car position signal with '1input per floor' display or lamps

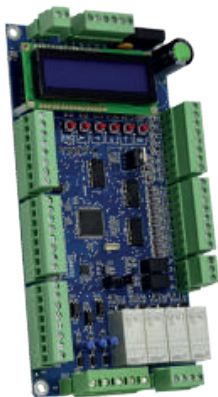

The **ELE-HL** is a control board for home and residential lifts.

- Compact and versatile, built in keypad and display.
- Minimises the number of external components to be fitted to the control panel.
- Suitable for both hydraulic and wire rope systems, with different types of drives and doors

SPECIFICATIONS:

- 5 optoinsolated inputs for safety chains.
- 48 digital inputs 0-24 VDC
- 6 Optoinsolated outputs for drive control
- 31 digital 24 VDC outputs protected against short circuits
- 12 relay outputs
- Preset for direct arrival to the floor
- Integrated USB port for PC interface

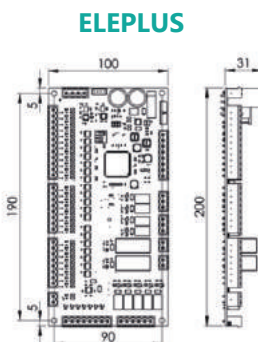
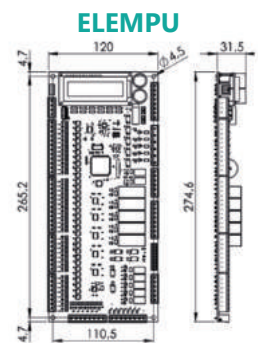

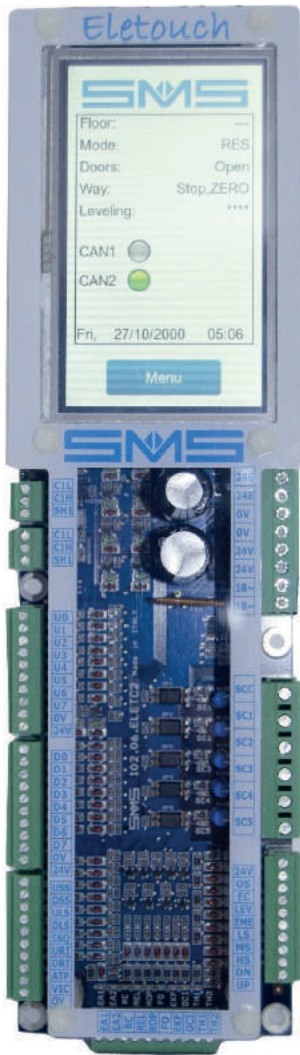

The **NAT10** is an electronic device with supply voltage from 200 to 500 Vac, 50 or 60 Hz, with two output relays (change-over contacts) that are designed to monitor:

- The correct sequence and the failure of one or more phases in a three phase system (relay 11-12-14)
- The temperature of motors with PTC output (relay 21-22-24)

The device has one yellow LED that signals the presence of the incoming supply; a green LED which shows the correct phase sequence and output activation, and a red LED to signal when the motor overheats.

Applications

The NAT10 can be used in any three phase motor control system, where a system has a phase failure, or overheating may cause damage to the machine, or generate a dangerous situation .i.e. pumps, compressors, lifts, cranes, etc.

Specifications

- Intrinsically safe circuit (output relays ON).
- Action delay time: 0.2 s.
- Automatic reset at recovering of normal conditions.
- Two change-over output contacts.

Operation

The output relays are show as on, if all the phases are present if the sequence L1-L2-L3, and when the motor is working at a temperature under the safe threshold.

The NAT10 turns the relay 11-12-14 off, when the phase sequence is wrong or if there is a failure of one or more phases. It also turns the relay 21-22-24 off, if the motor temperature passes the safe threshold.

The casing of the NAT10 is made by a glass-reinforced Bayblend, and it can be mounted on 35mm DIN rail (EN 50022).



Supply:

rom 200 to 500 Vac; 50/60 Hz

Power consumption:

< 5 VA

Contacts ratings:

3 (3) A, 250 Vac

PTC resistance (ohm):

minimum cold resistance: 100
max cold resistance
of PTC in series: 1500
average trip resistance: 2300

Expected life:

Electrical: 300.000 operations (nominal load)

Mechanical: 30 Millions operations

Protection: P20

Signalling:

Yellow LED: Power Supply
Green LED: Output relay 11-14 ON
Red LED: Over heating

Temperature range:

Operating: -10° C +55° C
Storage: -25° C +55° C

Installation:

DIN rail 35 mm (EN50022)

Connections:

Screws (Torque setting: 0,5 Nm)

Housing Material:

Bayblend (Polycarbonate+ABS
fiber glass reinforced)

Weight: 130 g

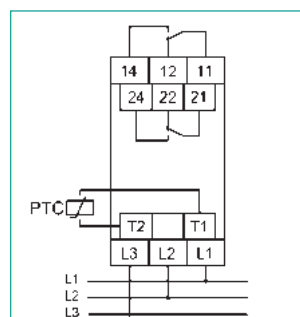
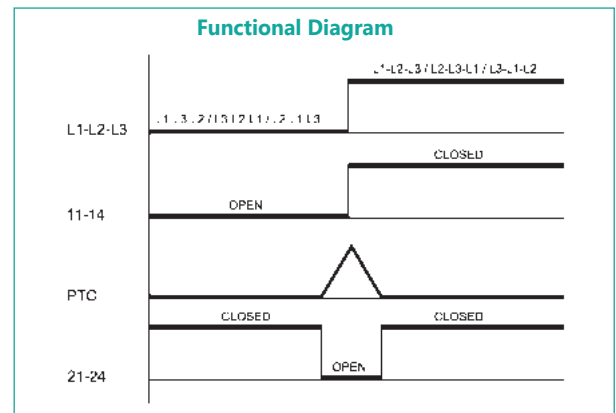

Control Components | NT10

Temperature Control Relay



The **NT10** is an electronic device with supply voltage of 230 Vac, 50 or 60 Hz, with an output relay (1 change-over contact) that is designed to control the machine room temperature of a lift. The output relay will switch on if the temperature is between 5 and 40°C (see functional diagram).

The main unit is made by a glass reinforced Bayblend, and can be mounted on 35mm DIN rail, the temperature probe is M25, threaded and made from fibre glass polycarbonate, with one green LED for input supply, and two red LEDs that signal the temperature conditions. The probe comes with nylon stop nuts and a fast connection cable, 2 meters in length. Fixing plates are also available on request.

Technical Data:

Supply:
230 Vac; 50/60 Hz

Contacts ratings:
3 (3) A, 250 Vac

Expected life:
Electrical: 300.000 operations (nominal load)
Mechanical: 30 millions operation

Referring standards:
The NT10 meets EN81 requirements, and is programmed to switch the control relay on between set temperatures of:
Minimum Temperature +5° C
Maximum Temperature +40 °C

Signalling: (on probe):
Green LED (ON): Power supply
Red LED (Tmin): Temperature below the minimum
Red LED (Tmax): Temperature over the maximum

Temperature range:
Functioning: -15° C +65° C
Storage: -30° C +80° C

Connections:
Screw terminals (Torque setting: 0,5 Nm)

Protection: IP20

Materials:
Central Unit: Bayblend
(Polycarbonate+ABS with fiberglass)

Probe: Makrolon
(polycarbonate with fiber glass)

Total weight: 250 g

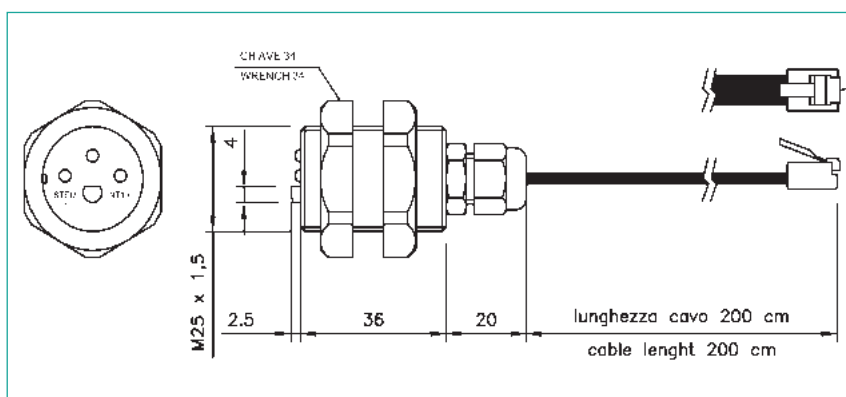
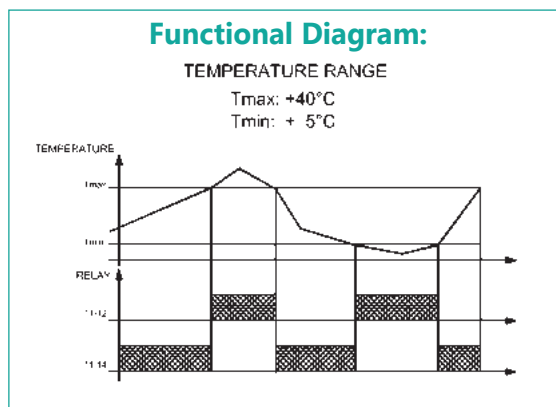

NT15 | Control Components

Temperature Control Relay with built in probe



The **NT15** is a temperature control unit which monitors the internal temperature of the control switchboard of lifts.

The NT15 will switch the output relay on, if the reading temperature is between the set amounts (see functional diagram).

The temperature probe is located on the front panel; along with three signalling LEDs: the green one for supply status, and two red to monitor the temperature conditions. The upper and lower temperature settings can also be changed using the relative dip-switches.

The NT15 has a 230V AC supply (50 or 60Hz) and a change over relay output. The casing is made from reinforced bayblend and can be mounted on 35mm DIN rail.

Technical Data:

Supply: 230 Vac; 50 or 60 Hz

Contact Ratings: 3 (3) A, 250 V ac

Expected life:

Electrical: 300.000 cycles (nominal load)

Mechanical: 30 Millions of operations

Signalling:

LED Green (PWR) : ON= Power ON

LED Red (Tmin) : ON : Temperature below the minimum

LED Red (Tmax) : ON : Temperature over the maximum

Temperatures:

Working: -15° C +65° C

Storage: -30° C + 80° CC

Connections:

Screw terminals (setting torque : 0,5 Nm)

Degree of Protection:

IP20

Housing Material:

Bayblend (Polycarbonate + ABS with fiber glass)

Weight: 120 g

Functional Diagram

TEMPERATURE RANGE

Tmax: +40°C, +45°C, +50°C, +55°C, +60°C

Tmin: -10°C, -5°C, 0°C, +5°C, +10°C

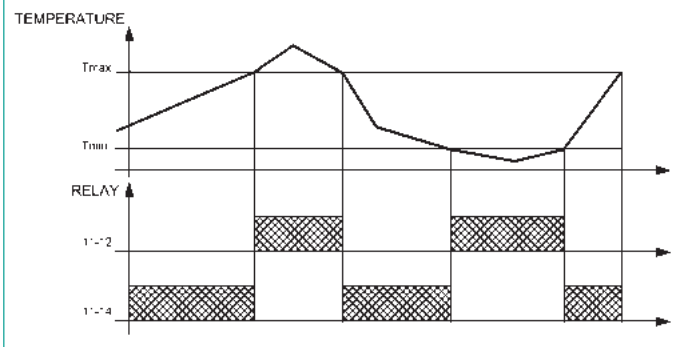

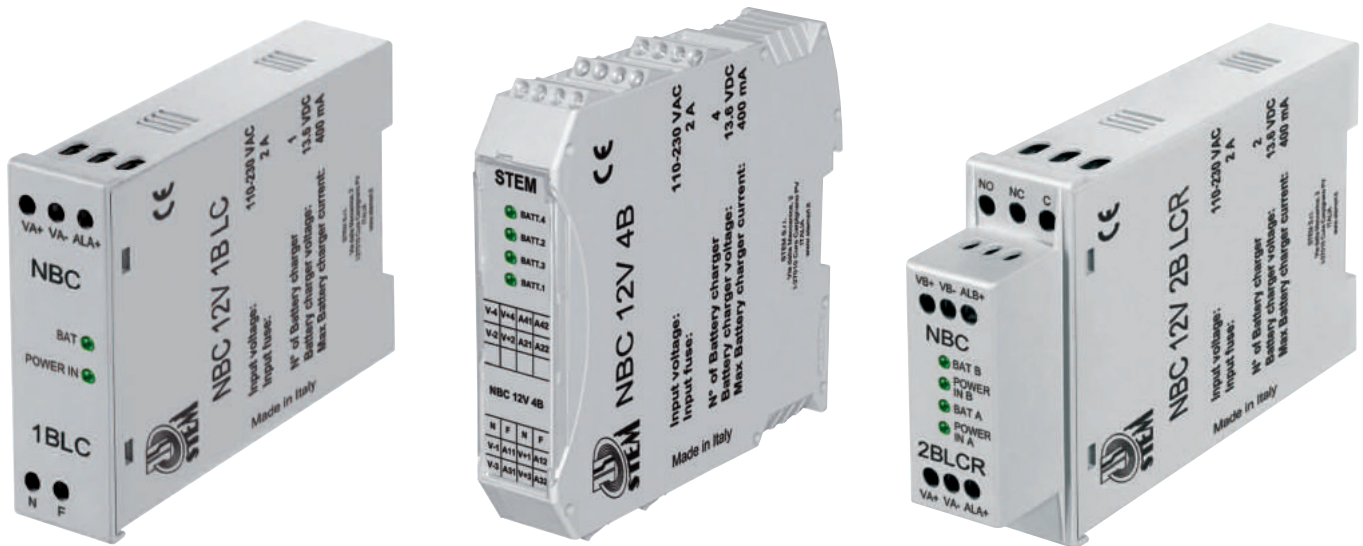

The **NBC 12V 2B LC** is a singular solution which is used to charge one battery or two independent batteries.

Suitable for Batteries 12V 7Ah (Acid Lead):

NBC 12V 2B LC is the ideal solution to recharge and monitor 12V batteries, it can remain connected to the battery without posing any risks, and without having to disconnect the battery from any connected equipment.

This ensures the battery is always charged over long periods of time (up to months as idle period)

NBC 12V 2B provides a maximum current up to 0.4 A, and is suitable for standard batteries (acid lead) where the normal charge could be evaluated at 0.036A per each Ah of capacity.

The NBC12V can be supplied as a 1, or 2 battery charger.

Main features:

- Charge up to two independent batteries simultaneously.
- Recharge up to two batteries at a time, detecting the drained ones.
- To monitor the battery status during normal function (in presence of main voltage).

LEDs:

- Battery charged (LED)
- Battery recharging (LED)
- Battery not present (LED + OUTPUT)
- Battery exhausted (LED + OUTPUT)
- Battery element short circuit (LED + OUTPUT)
- To survey the battery status during emergency condition (lack of main voltage)

Showing:

- Correct battery working voltage (LED)
- Battery working voltage under threshold (LED + OUTPUT)
- LED light indication for each channel.
- Only one opto-isolated output for remote alarm per each single stage (battery).
- Input voltage range 110/265 Vac
- Maximum charging current: 300 mA (1B / 2B); 400mA (4B).
- Short circuit protection with automatic restart after short circuit removal (each stage is independent).
- Over current protection with automatic restart after over current removal (each stage is independent).

The 2BLCR version allows a relay output to signal failure of power, in this case 110Vac and 230Vac are the only options available.

| Signalling Battery Status | | | | |
|---|------------------------|--------------------------------|------------------------------------|--|
| Battery status during normal function (in presence of main voltage) | | | | |
| Battery status | (LED) | Uscita allarme Output Alarm | Descrizione Description | |
| Battery disconnected or short circuit | ● ON Red | Alarm ON (Closed) | Voltage lower than 11.5V | |
| Battery connected and charged | ● ON Green | Alarm OFF (Open) | Voltage higher than 12.8V | |
| Battery connected in charge | ● Blink Red ● Green | Alarm OFF (Open) | Voltage in the range 11.5V – 12.8V | |
| Battery status during emergency condition (lack of main voltage) | | | | |
| Battery status | (LED) | Output Alarm | Description | |
| Battery worn out | ● ON Red | Alarm ON (Closed) | Voltage lower than 9.5V | |
| Battery connected and charged | ● ON Green | Alarm ON (Open) | Voltage higher than 9.5V | |

Technical Data:

Supply Voltage:

110-220 Vac (50-60Hz)

Charge supply voltage (no load):

13,9 Vdc

Internal fuse on the supply

2A fast fuse

Current Consumption:

@220 Vac: 90mA

Operating Conditions:

Temperature: 0 to +50°C

Relative humidity: 4% to 100%

Pressure 86 to 106 kPa

Housing Conditions:

Temperature: -40 to +120°C

Relative humidity: 5% to 95%

Pressure 86 to 106 kPa

Degree of Protection:

Housing OP20

Assembly:

35mm DIN

Full charging time:

24 Hr

Connection type:

Screw terminals

Housing Material:

Bayblend (PC + ABS fiber glass reinforced)

Weight:

200g

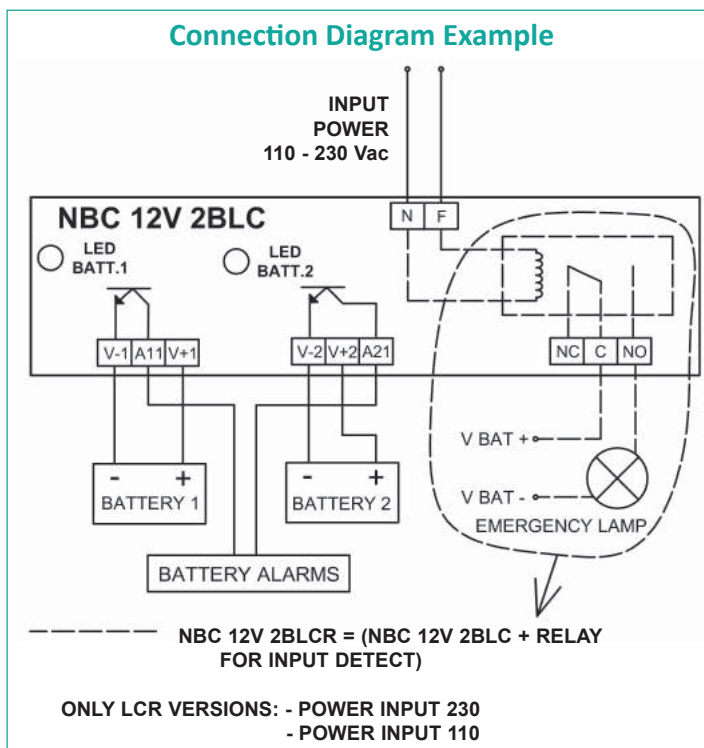

| Code | Characteristics |
|------------------------|--|
| NBC 12V 1BLC | Standard version with supply voltage from 110 Vac to 230 Vac |
| NBC 12V 1BLCR110 / 220 | Relay version with supply voltage of 110 / 220 Vac |
| NBC 12V 2BLC | Standard version with supply voltage from 110 Vac to 230 Vac |
| NBC 12V 2BLCR110 / 220 | Relay version with supply voltage of 110 / 220 Vac |
| NBC 12V 4B | Standard version with supply voltage from 110 Vac to 230 Vac |

Control Components | NC80

Safety Control Unit



The **NC80** is an electronic control unit specifically designed to be used in the lifts safety circuit; this module is based on the use of guided contact safety relays. The modules have two control inputs S1 and S2 that, if activated in a time gap of 1.8 seconds, leads to the commutation of the three outputs (2 normally open and one normally closed).

In particular it is possible to connect to the two inputs to two normally open STEM magnetic sensors that are approved by TÜV for the use in a lifts safety circuits (EN81-20).

The output remains active until the two inputs are closed (see timing diagram). The safety is guaranteed by the use of guided contacts, redundancy and the interconnection wiring diagram of the contacts.



Technical Data:

Supply:

24 Vdc ±10%

Maximum power consumption:

1,7 VA

Input synchronisation time(ts):

1,8 s Response Time:
50 ms

Signalling:

LED S1 (Green) = Sensor 1status:

ON active; OFF not-active.

LED S2 (Green) = Sensor 2status:

ON active; OFF not-active.

LED OUT (Red) = Output status:

ON active; OFF not-active.

LED Power (Yellow) = Supply status:

ON power-on; OFF Power-off.

Outputs:

Safety outputs:13-14 N.O.;23-24 N.O.

Auxiliary Output: 41-42 N.C.

Ratings:

3 (3) A, 250 V ac

Weight: 200 g

Connections:

Screw terminals (setting torque: 0,5 Nm)

Temperatures:

Working: 0°C +55° C

Storage: -20° C +70° C

Degree of protection:

IP20

Housing material:

Bayblend (Polycarbonate +ABS + fiber-glass);

Mechanical life:

108 operations.

Timing Diagram

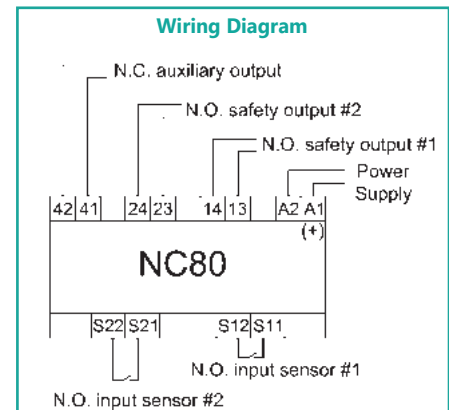
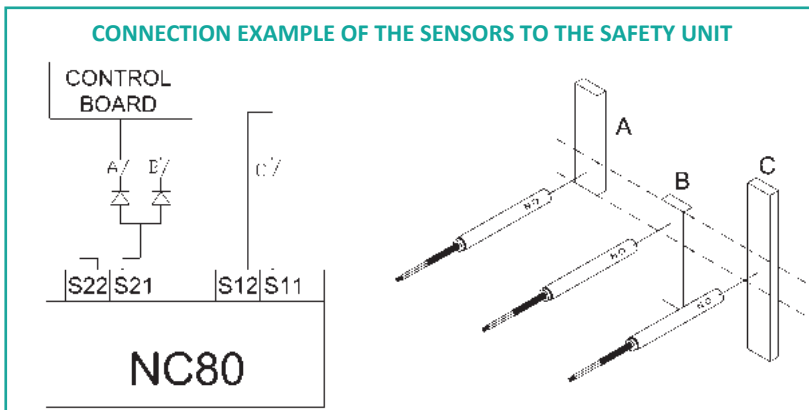
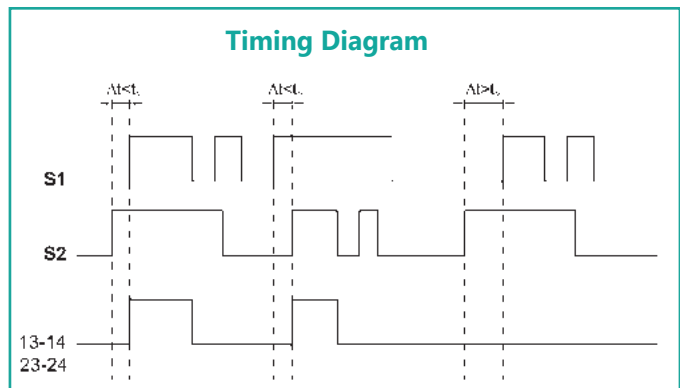

The **IP67** door safety system replaces the standard system with a removable bridge, and eliminates defects making it exempt from mechanical wear caused by dirt and foreign objects that can cause damage and common problems that occur with electro mechanical contacts.

In every sensor, contacts are present that give the equivalent output as two separate normally open signals. The normally open signal (indicated by brown and white cables) should be connected in line with the contacts represented by the same wires on other sensors.

The same should be done for normally open signals, with green and yellow cables. The two independent series of normally open contacts become the inputs for the NC80. When this sensor gives two closed signals within a set amount of time, it will activate the safety and signalling outputs for the control board.

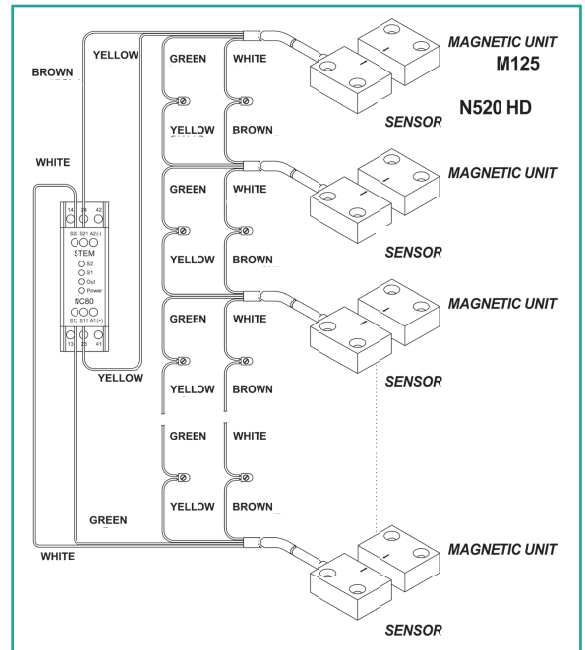
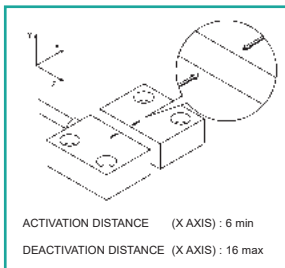
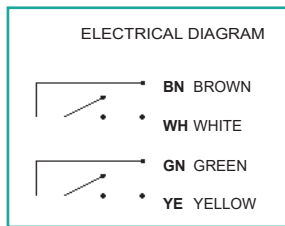
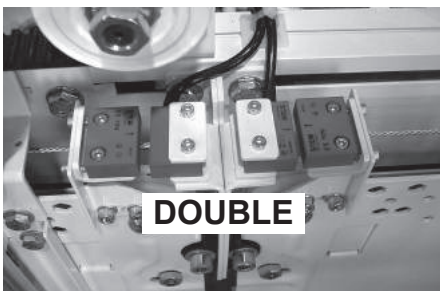
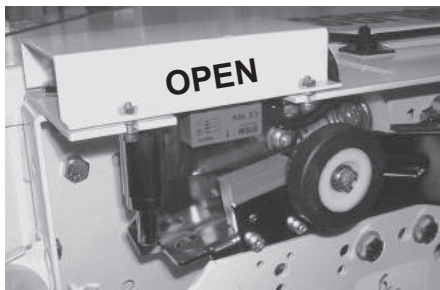
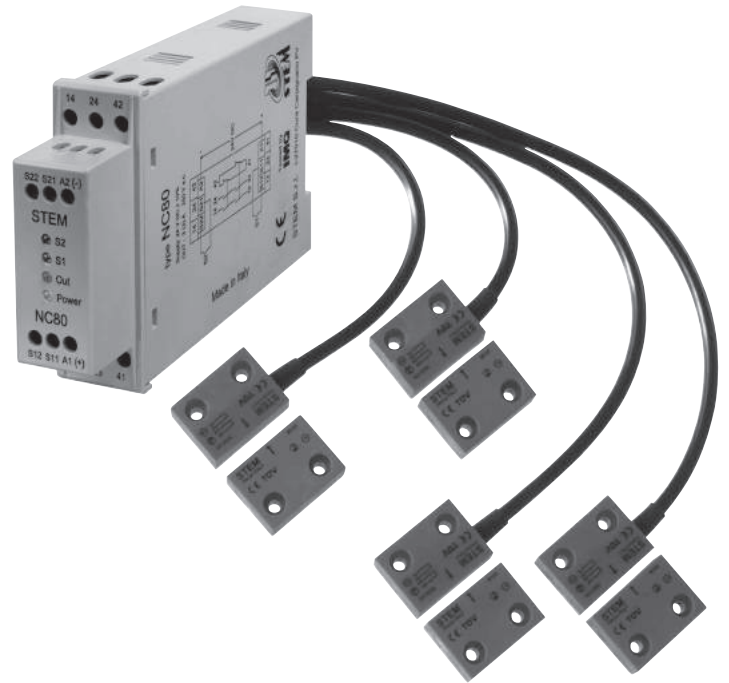

| Parameter | Value |
|----------------------|--|
| Housing material | Glass-fiber reinforced SPS |
| Ambient temperature | -20 ... +100 °C |
| Degree of protection | IP 67 (IEC 60529) |
| Connection type | Cable with terminals |
| Switching voltage | 24 ± 10% V |
| Switching current | 0,5 A |
| Mechanical life | 100x10 ⁶ cycles |
| Vibration resistance | in accordance EN 60947-5-2 |
| Shock resistance | in accordance EN 60947-5-2 |
| EMC compliance | in accordance EN 61496-1 / EN 50022 part A |

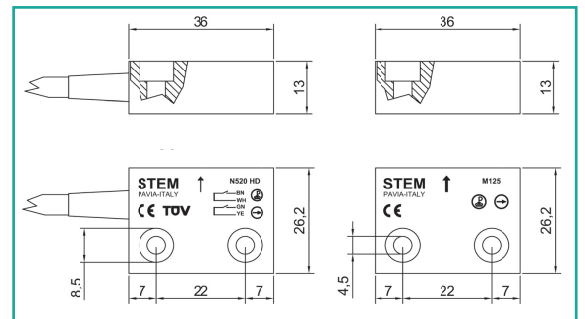

Control Components | NC85

Safety Control Unit for Levelling

The **NC85** Module can control the state of two magnetic sensors (Reed or Hall effect): the output is activated by pressing the START button however the contacts on both sensors must be closed.

The opening of even only, one input contact (S1 and/or S2), leads to a safety situation, by putting the safety outputs in open state and by preventing the closing of the contacts.

The START button can be excluded (automatic rearmament) by short-circuiting the relative input contacts; in this case, to close the safety outputs the two contacts S1 and S2 must close in a time interval of maximum 0.6 sec.

The control unit has an opto insulated normally opened signal output (31-32).

It is available as input (X1-X2) for feedback with contactors or external relays.

The safety is ensured by using guided contacts, by the redundancy and by the interconnection schematic of the contacts.

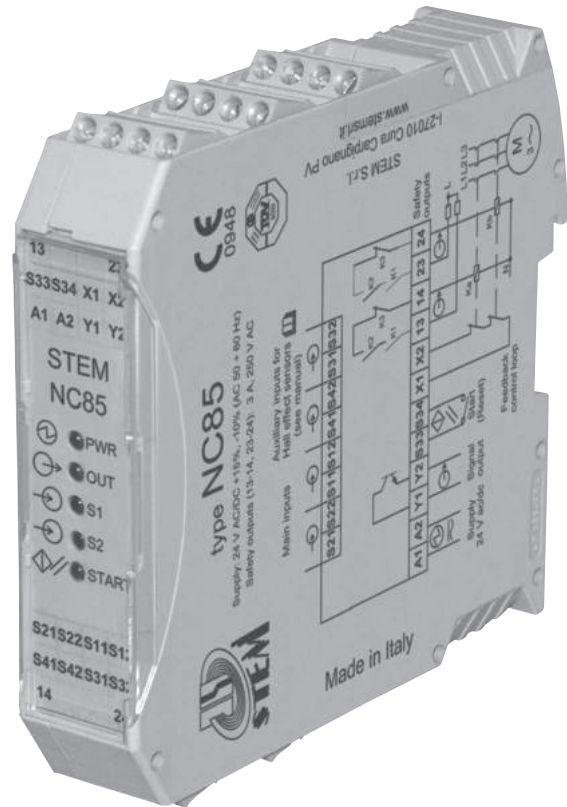

Technical Data:

Supply:

24 Vac/dc +15% -10%

Maximum Current Consumption:

100 mA

Input Synchronisation Time

(with automatic rearmament):
600 ms

Response Time (ts):

600 ms

Signalling:

LED POWER (Green) = Supply status:
ON power-on; OFF Power-off.

LED OUT (Green) = Output status:
ON active; OFF not-active.

LED S1 (Green) = Sensor 1 Status:
ON active; OFF not-active.

LED S2 (Green) = Sensor 2 status:
ON active; OFF not-active.

LED START (Green) = Start Button Status

Ratings:

3 A, 250 V ac

Housing material:

PA 6.6

Outputs:

Safety outputs: 13-14 N.O.:23-24 N.O.

Auxiliary output: Y1-Y2 N.O. opto-insulated;

Temperatures:

Working: 0°C +55° C

Storage:-20° C +70° C

Connections:

Screw terminals (setting torque: 0,5 Nm)

Degree of protection:

IP20

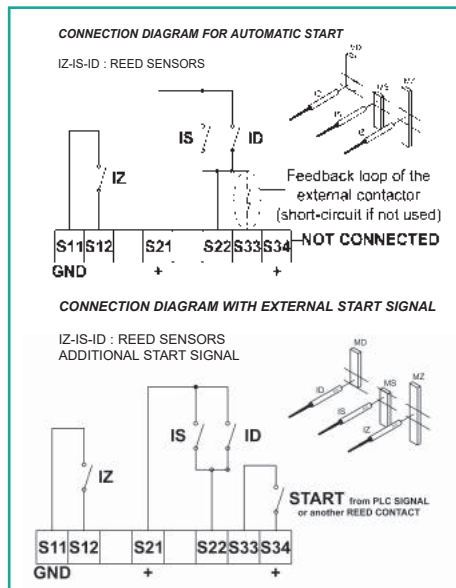

CONNECTION DIAGRAM TO HALL EFFECT SENSORS

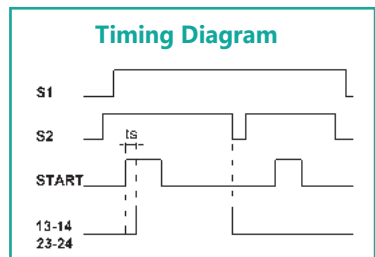
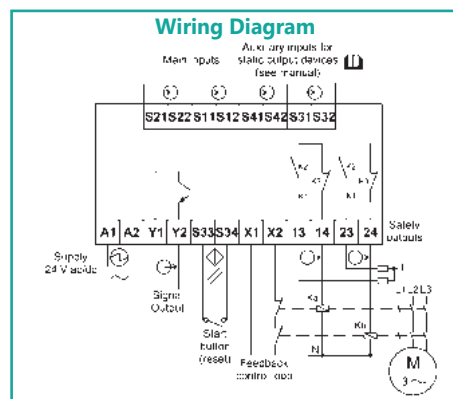
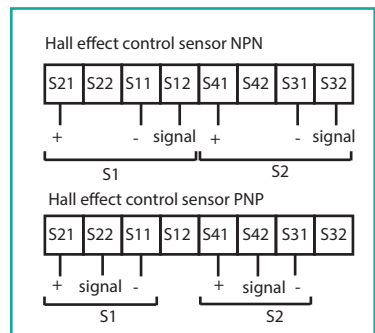

The **NC96** is a safety unit which controls the state of two reed magnetic sensors. The output is activated by pressing the start button, however the sensor contacts must be closed.

The opening of even only one input contact (S1 and/or S2), leads to a safety situation, by putting the safety outputs in the open state. The safety outputs will remain as such, incase a new contact closes (S1 e/o S2).

The control unit has an opto-insulated normally closed signal output (31-32).

Input is available (Y1-Y2) for feedback with external contactors or relays.

The safety is ensured using guided contacts, by the redundance and by the interconnection schematic of the



Technical Data:

Supply:

24 Vac/dc +15% -10%

Maximum Current Consumption:

100 mA DC; 500 mA AC.

Input Synchronisation Time

(with automatic start):

Response Time (ts):

30 ms

Signalling:

LED POWER (Green) = Supply status:

ON power-on; OFF Power-off.

LED CH1-CH2 (Green) = Output status:

Both ON active; Both OFF not-active.

Outputs:

Safety outputs: 13-14 N.O.; 23-24 N.O.

Auxiliary output: 31-32 N.C.

optoinsulated;

Ratings:

3 A, 250 V ac

Mechanical life:

107 operations.

Temperatures:

Working: 0°C +55° C

Storage: -20° C +70° C

Connections:

Screw terminals (setting torque:

0,5 Nm)

Degree of protection:

IP20

Housing material:

PA 6.6

Weight:

160 g

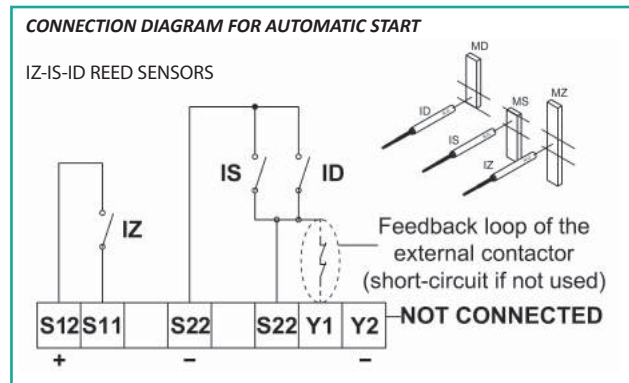
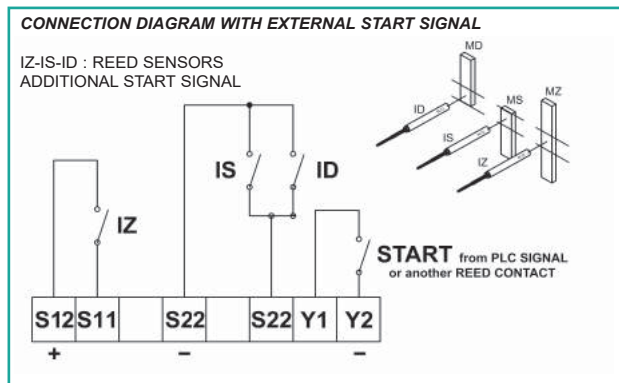
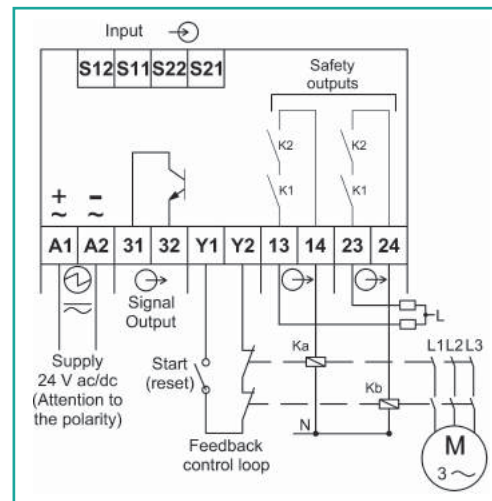
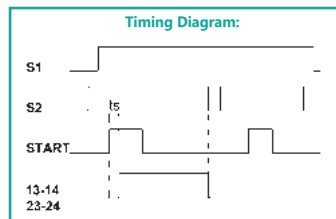

Control Components | NC96

Control Units for Safety Mats



The **NC95** Module is used to control pressure sensitive safety mats. The safety outputs are closed by pushing the START (reset) button, however only if the 2 inputs are closed and there is no pressure on the safety mat area.

When there is pressure on the mat, the unit will open the safety outputs 13-14 and 23-24. The manual reset is possible if there is no pressure on the mat.

The NC95 can be used only with manual start (reset); to configure the system with automatic start. The opening of even only, one input contact, leads to a safety situation, by putting the safety outputs in open state and by preventing the closing and the start button being pressed.

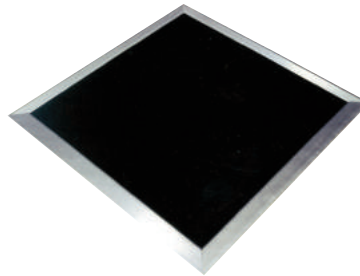

Technical Data:

Supply:

24-15% + 10% Vac/dc (AC 50-60 Hz)

Dimensions:

114.5 x 99 x 22.5 mm

Working Environment Conditions:

Temperature: -25 to + 70 °C
Relative humidity: 5% to 95%
Pressure: 86 to 106 kPa

Degree of protection:

IP40
EN81:20

External fuse on output:

4A

Safety output terminals:

13-14, 23-24

| Function | LED | Color | State |
|------------------------------|-----|-------|-------|
| Operating voltage | PWR | green | on |
| Outputs 13-14, 23-24: OPEN | CH1 | green | off |
| Output 31-32: CLOSED | CH2 | green | off |
| Outputs 13-14, 23-24: CLOSED | CH1 | green | on |
| Output 31-32: OPEN | CH2 | green | on |

Assembly:

35mm DIN

Connection type:

Screw terminals

Safety outputs switching voltage:

240Vac (MAX)

Electrical Life:

108 Cycles

Minimum switching current @ 10V:

10 mA

Safety output switching power:

720VA (MAX)

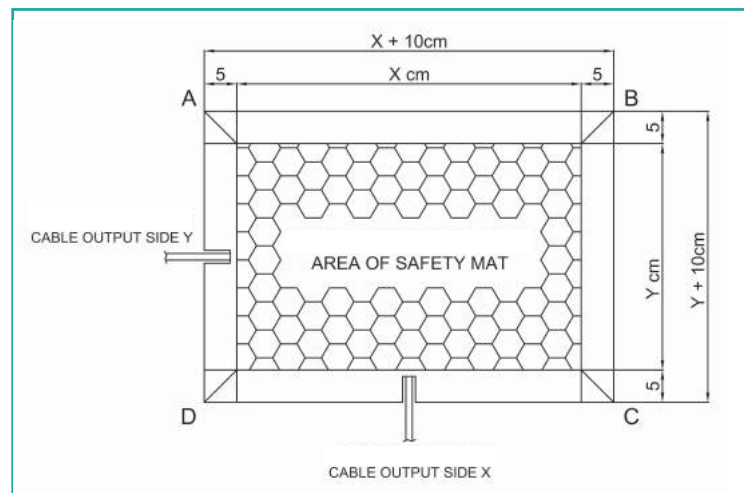

SIZE AND TECHNICAL CHARACTERISTICS

| | |
|------------------------|---|
| Standard sizes: | 1000 m 1250 m 1450 m |
| Modular | |
| Thickness: | 9 mm approx. |
| Weight: | 8,9 kg/m ² approx. |
| Colour: | grey |
| Material: | flexible, self-extinguishing PVC |
| Type of structure: | ribber / groover treadable surface |
| Features of the cable: | Flexible, flame-proof IEC 332.3A IEC 20-22 with numbered, black insulation, cross section 1 mm ² |
| Type of cable: | 4-wire (for safety mat) 2-wire (for regular mat) |
| Cable Length: | 2 m, standard length any length on request up to 30 m |

| | |
|--|---|
| Type on lead wire ending: | cut |
| Degree of protection: | IP 65 |
| Total surface of mats that can be connected to a single control device: | 20 m ² max. more than 13 kg on a circular area 80 mm across |
| Mat sensitivity: | category 3 with control unit NC 95, NC 96 omologated in category 4 |
| Safety category: | EN81:20 |
| Response time: | 9 ms (only mat) 30 ms (NC 95 o NC 96) |
| Supply: | 24 VDC ± 10% |
| (For stand alone use) | |
| Operating Life: | more then 5.000.000 cycles |
| Please note: the pressure-sensing safety mat cannot be used to detect the intrusion of person moving on crutches or wheelchairs. It cannot be placed on the route of moving fork-life trucks, if there is any chance that the latter should pivot on the surface of the mat to change direction. | |

The **NCUM20** is a safety device used to detect the uncontrolled movement of elevators in accordance with EN81:20. The operation of the module is based on the used of guided safety relay contacts. It is used for uncontrolled movement and levelling control.

Independent Levelling:

Occasionally an application is needed to separate the elevator levelling from the uncontrolled movement detector, to avoid the controller putting the lift out of order when exiting the levelling zone. This is where the NCUM20 should be used, as it is a control unit for levelling, but with 2 extra contacts.

The levelling unit output, in parallel with the safety door contact, make the input C11 (opto-insulated).



The magnet used to activate the sensor (wired to S11-S12, S21-S22) must be positioned so the activation distance will be greater than the activation of the levelling control unit sensors. If the input PS2 is connected before the car door contact, the NCUM will automatically close the outputs (13-14/23-24) in case the car door safety contact has been opened (if it is an intended car door movement). If the power supply sensor PS2 is not used the door contact has to be wired at the beginning of the elevator safety circuit.

With/Without Levelling:

The NCUM20 has a levelling function as well as the uncontrolled movement function. The safety door contact should be wired in parallel with outputs 53-54, as well as levelling with open doors, in case it is needed. This is connected to input C11 (opto-insulated). If levelling is not required, the outputs 43-44 must be wired to the input S41, if the input PS2 is connected before the car door contact the NCUM will automatically close the outputs (13-14/23-24) in case a safety contact has been opened (if it is an intended movement). If the power supply sensor is not used the door contact should be wired at the beginning of the of the elevator safety circuit.

The NCUM20 monitors the signal status of the inputs, and if a dangerous event occurs it will open the safety outputs 13-14/23-24. The unit also allows levelling operation with open doors. Monitoring inputs S11-S12 and S21-S22 it will open the safety contacts 43-44/53-54 if the car moves out of the door zones.

| TECHNICAL DATA | |
|--|---|
| Parameter | Value |
| Housing material | PA |
| Dimensions | 160,5 x 96 x 63,5 (height) mm |
| Weight | 250 g |
| Operating conditions | Temperature: -5 ... +55 °C |
| | Relative humidity: 4% ... 100% |
| | Pressure: 86 ... 106 kPa |
| Housing conditions | Temperature: -25 ... +70 °C |
| | Relative humidity: 5% ... 95% |
| | Pressure: 86 ... 106 kPa |
| Degree of Protection (IEC 60529) | Terminals: IP20 / Housing: IP40 |
| Degree of contamination | 2 |
| Assembly | 35 mm DIN standard ra |
| Connection type | Screw terminals |
| Supply voltage | 24 -15% / +10% (AC 50 + 60 Hz) Vac/dc |
| Battery supply voltage | 12 -15% / +10% Vdc |
| Internal fuse on the supply | 750 mA PTC fuse |
| External fuse on battery supply (A3, +12V) | 500 mA fast blow fuse |
| Current consumption | @24Vdc: 25 min, 100 max; @24 Vac 110 min, 220 max mA |

| TECHNICAL DATA | |
|--|--|
| Parameter | Value |
| Safety outputs switching voltage | 240 (max) (Safety output) Vac |
| Switching current AC-1 / Electrical life | 3 (Safety output) / >10 ⁶ cycles A |
| Minimum switching current @ 10 V | 10 mA |
| Safety output switching power | 720 (max) VA |
| External fuse at the output | 13-14, 23-24, 43-44, 53-54 4 A gG (according to IEC EN 60269-1) |
| A3 uncontrolled movement safety output contacts | 13 - 14 / 23-24 |
| Auxiliary uncontrolled movement safety output contacts | 31 - 32 NC 31 - 33 NO |
| Safety/levelling output contacts | 43 - 44 / 53-54 |
| Auxiliary levelling output contacts | 61 - 62 NC 61 - 63 NO |
| Usage category / Electrical Life (SAFETY outputs) | AC-15: 1,4 A / 240 V (inductive load, cos ^φ = 0,3) / 10 ⁶ cycles DC-13: 1A / 24 V / 10 ⁶ cycles |
| Auxiliary outputs parameters | max: 0,5A @24 Vdc |
| OFF state response time | 20 ms |
| Max input sensor resistance | 200 ohm |
| Vibration resistance | EN 60068-2-6:1996 EN81-20 |
| Mechanical life | 10 ⁶ cycles |
| EMC compliance | UNI EN 12015:2005, UNI EN 12016:2005 |
| In accordance with | EN81-20 |

Control Components | NCUM50

Safety Unit for Uncontrolled Movement



The **NCUM50** is a safety device used to detect the uncontrolled movement of elevators in accordance with EN81:20. It operates based on the use of guided safety relay contacts. It is a levelling unit, specifically for applications with speed limiters, as it is able to distinguish an uncontrolled movement from a power supply failure on the safety circuit or the opening of a contact above the door contact.



The NCUM monitors the status of inputs C11, C12, C13, C14 if:

- There is a voltage at the terminals C13, C14 but not at C11 terminals which indicates that the car door is open, so if the lift were to move out of the door zone an uncontrolled movement will be detected and output 13-14, and 23-24 will open engaging the locking electro mechanical system (OSG and safety gear).

- There is no voltage at terminal C14, which means that there may have been a power supply failure or accidental contact opening close above the door contacts on the circuit. In this situation the outputs 13-14 will remain closed, which stops the safety gear engaging while the elevator stops, causing a dangerous situation. Meanwhile the output 23-24 will open. The missing wiring or a fault in the input C14 will prevent the system recognising an uncontrolled movement, however in this situation if the outputs 23-24 (in series on the safety circuits) are open the departure of the lift is prevented.

- The voltage is present at terminal C14, but lacks at terminal C13, which means that there was an opening of the landing door. If this occurs the 13-14 output will open with a delay of roughly 2 seconds, which allows the lift to stop using the brakes, avoiding use of the safety gear. If there is a temporary failure of the power supply, the NCUM will continue to operate as it is connected to the battery. The output 13-14 will be closed allowing a manual rescue operation. The NCUM50 allows levelling operations to occur with the doors open (use connection diagram fig.2). By monitoring the inputs, S11-S12 and S21-22 will open safety contacts 43-44 when the car is moving out of the door zone.

The OSG manufacturer suggests the release of the electromagnet when the lift is stopped at a floor, the lift control panel should cut the power supply to the electromagnet via a relay contact (KX). The normally closed contact of the electromagnet position sensor must be wired in series with the safety chain to avoid activating the safety gear.

Stopping device monitoring:

The NCUM manages the monitoring and stopping elements. It will send a test pulse to the 'T' inputs, the safety output contacts 13-14 will open, activating the solenoids lock of the speed governor. If it works properly, a signal of successful implementation will be sent to the 'R' input, the NCUM will then close the safety outputs 13-14.

The feedback signal on the 'OT' output, will check that the lift controller has activated the correct stopping device, while the impulse on the microswitch M1 will check it is functioning correctly. It can also be used to check that the solenoid lock returns to the off position. The microswitch M1 must have positive opening contacts. The NCBMO1 (see pg.84) allows management of the monitoring procedures.

| TECHNICAL DATA | |
|--|---|
| Parameter | Value |
| Housing material | PA |
| Dimensions | 155,5 x 91 x 61,3 (height) mm |
| Weight | 250 g |
| Operating conditions | Temperature: -5 ... +55 °C |
| | Relative humidity: 4% ... 100% |
| | Pressure: 86 ... 106 kPa |
| Housing conditions | Temperature: -25 ... +70 °C |
| | Relative humidity: 5% ... 95% |
| | Pressure: 86 ... 106 kPa |
| Degree of Protection (IEC 60529) | Terminals: IP20 / Housing: IP40 |
| Degree of contamination | 2 |
| Assembly | 35 mm DIN standard rail |
| Connection type | Screw terminals |
| Supply voltage | 24 -15% / +10% (AC 50 + 60 Hz) Vac/dc |
| Battery supply voltage | 12 -15% / +10% Vdc |
| Internal fuse on the supply | 750 mA PTC fuse |
| External fuse on battery supply (A3, +12V) | 500 mA fast blow fuse |
| Current consumption | @24Vdc: 25 min, 100 max; @24 Vac: 110 min, 220 max mA |
| Safety outputs switching voltage | 240 (max) (Safety output) Vac |
| Switching current AC-1 / Electrical life | 3 (Safety output) / >10 ⁶ cycles A |
| Minimum switching current @ 10 V | 10 mA |

| TECHNICAL DATA | |
|--|--|
| Parameter | Value |
| Safety output switching power | 720 (max) VA |
| External fuse at the output 13-14, 23-24, 43-44, 53-54 | 4 A gG (according to IEC EN 60269-1) |
| A3 uncontrolled movement safety output contacts | 13 -14 |
| Auxiliary uncontrolled movement safety output contacts | 31 - 32 NC; 31 - 33 NO |
| Safety levelling output contacts | 43 -44 |
| Auxiliary levelling output contacts | 61 - 62 NC; 61 - 63 NO |
| Elevator safety circuit output contact | 23 - 24 |
| Usage category / Electrical Life (SAFETY outputs) | AC-15: 1,4 A / 240 V (inductive load, cosΦ= 0,3) / 10 ⁶ cycles DC-13: 1A / 24 V / 10 ⁶ cycles |
| Auxiliary outputs parameters | max: 0,5A @24 Vdc |
| Output (13-14) response time in case of uncontrolled movement | 20 |
| Output (13-14) response time in case of landing door opening outside the floor level | 2 |
| Output (13-14) response time in case of car door opening outside the floor level | 20 |
| Output (43-44) response time for the levelling | 20 |
| Max input sensor resistance | 200 ohm |
| Vibration resistance | EN 60068-2-6:1996 EN81-20 |
| Mechanical life | 10 ⁶ cycles |
| EMC compliance | UNI EN 12015:2005, UNI EN 12016:2005 |
| In accordance with | EN81-20 |
| Approval | TuV SUD DCI xxx |

The **NCBM01** is used to recognise the automatic monitoring systems of built in redundancy devices, as detailed in EN81-20.

For hydraulic elevators: the NCBM01 allows periodical monitoring of the function of the two down direction valves, connected and controlled in sync. It also allows the activation and deactivation of the single additional A3 valve with different timing, in comparison with the standard down direction valve.

For traction lifts with A3 brakes: the NCBM01 monitors the safety micro switches on the brakes of a gearless machine.

For traction lifts with A3 device on the OSG (over speed governor): the NCBM01 monitors the functionality of the blocking element (electromagnet) installed on the OSG.

All the stopping elements must be certified ie. down direction valves, electrical brakes, and the over-speed governor (OSG).

Main features:

- The NCBM01 will activate the output relay if the test fails.
- Reset button to manually restore system to normal after alarm activation.
- HW redundant circuitry of the micro-controller section that will activate the alarm relay whenever a test has not been performed within 38 hours.
- Internal clock for time configuration.
- Hour configuration using a button.
- 6 LEDs to signal alarms and operating status.
- USB port and software application for configuring the unit allowing maximum flexibility to insert test and operational parameters. During system assembly fast parameter download is made possible by selecting the appropriate file

System with a single valve A3

Some valve manufacturers occasionally have an additional A3 valve block which must be opened, then closed before the main valve (descent). The NCBM01 allows the sequence to be configured and allows delays to activation or deactivation between the 2 valves.

Systems with a double valve

When double valve systems are monitored and controlled in parallel, the NCBM01 can perform a sealing test.

Functioning as a monitoring system electric brakes

If the elevator is equipped with electric brakes (certified A3), it is possible to monitor the safety microswitch on the brakes at each change of state (open/close). On each lift travel, the NCBM controls the status of the microswitch, and if an anomaly is detected, it triggers the alarm which can be reset via the manual button. The microswitch can be normally closed (NC) or normally open (NO).

Functioning as a monitoring for over speed governor

NCBM01 is able to perform monitoring on the existing types of A3 blocking systems mounted on the OSG:

1. Electromagnet Coil released and activated and each arrival/departure from the floor.
2. Electromagnet Coil always activated and released only in the event of uncontrolled movement.

In the first case NCBM checks the microswitch assembled on the OSG at each activation/deactivation of the electromagnet. In the second case, NCBM at a specified hour, opens the electromagnet power supply and by means of the microswitch, it will check the correct operation of the device.



TECHNICAL DATA

| | |
|--|---|
| Power supply: | 15-30V AC/DC 3W |
| Voltage inputs maximum on the connectors: PO, PT, V, D, S. | 24 ÷ 220 VAC / 24 ÷ 110 VDC |
| Maximum switching capability at alarm fault output | 220 VAC, 60 W |
| Maximum switching capability outputs O1-O2 | 400 VAC, 500 W |
| Working temperature | +0° ... + 70 °C |
| USB interface | MINI USB typeB 5 contact. |
| Battery type | 3V - 220mAh 2032 type (diameter 20 mm) |
| Battery life in stand-by | 20 days |
| Mechanical Dimensions | Box ME MAX22, 1P 20 Thickness 22,5 mm Height 125 mm Width 105 mm |
| Mechanical Fixing System | DIN Type |
| Storage Temperature | -40°C + 120°C |
| EMC compliance | EN 12015:2005 – EN 12016:2005 |
| In accordance with | EN81-1:1998+A3:2009 EN81-2:1998+A3:2009 |
| Approvals | IMQ certificate pending |



Find us online!
www.taylorlifts.co.uk

enquiries@taylorlifts.co.uk

0115 714 1113

Unit 3, Canalside Industrial Park, Kinoulton Road, Cropwell Bishop, Nottingham, NG12 3BE