

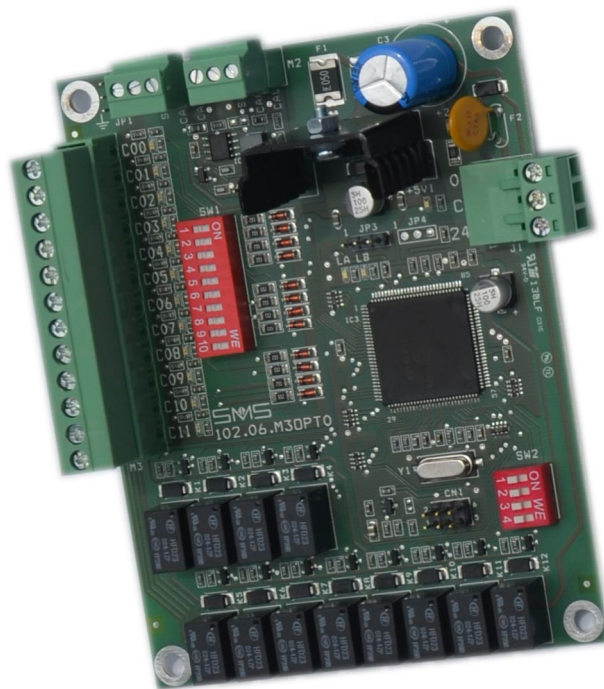

## Expansion Board

# ELEXP

## INSTRUCTION MANUAL



<b>00</b>	17-03-2016	D. Cavalli
REL.	DATE	T.M. Check and Approval

## TABLE OF CONTENTS

1 - INTRODUCTION.....	Page 3
2 - DIMENSIONS AND FASTENING.....	Page 3
3 - ELECTRICAL SPECIFICATIONS .....	Page 4
4 - ELEXP AS EXPANSION CARD FOR CAR AND LANDING CALLS .....	Page 5
4.1 - PARALLEL CONFIGURATION WITH THE ELEMPU BOARD.....	Page 5
4.2 - CONFIGURATION WITH SERIAL CONNECTION TO THE CAR (ELEMPU + ELEPLUS BOARDS) .....	Page 6
5 - ELEXP AS DECODER FOR “7 SEGMENTS” DISPLAY .....	Page10
6 - ELEXP AS DECODER FOR “1 INPUT PER FLOOR” DISPLAY.....	Page11

# 1 – INTRODUCTION

ELEXP is an expansion board for the ELESYS System, a versatile and small size card.

It is connected to the main boards (ELEMPU and ELEPLUS) via CAN BUS, and it can be used for the following applications:

- Expansion of car and landing calls, in order to manage the collective operation up to 32 stops.
- Decoder for car position signal with “7 segment” display.
- Decoder for car position signal with “1 input per floor” display or lamps.

ELEXP Boards with different functions may exist in the same lift control panel.

The possible configurations with the ELEXP board used to extend the maximum stop number are summarized in the following Table:

## ELESYS SYSTEM WITH ELEMPU – ELEPLUS – ELEXP BOARDS MAXIMUM STOP NUMBER

### A) PARALLEL CONFIGURATION

CONTROL PANEL Boards	ELEMPU	ELEMPU + n°1 ELEXP	ELEMPU + n°2 ELEXP	ELEMPU + n°3 ELEXP	ELEMPU + n°4 ELEXP	ELEMPU + n°5 ELEXP	ELEMPU + n°6 ELEXP
HOME LIFT	8	---	---	---	---	---	---
AUTOMATIC PUSH BUTTON	12	---	---	---	---	---	---
DOWN COLLECTIVE	12	18	24	30	32	---	---
FULL COLLECTIVE	8	12	16	20	24	28	32

### B) CONFIGURATION WITH SERIAL CONNECTION TO THE CAR

CONTROL PANEL Boards	ELEMPU	ELEMPU + n°1 ELEXP	ELEMPU + n°2 ELEXP	ELEMPU + n°3 ELEXP	ELEMPU + n°4 ELEXP
CAR Boards	ELEPLUS	ELEPLUS + n°1 ELEXP	ELEPLUS + n°1 ELEXP	ELEPLUS + n°1 ELEXP	ELEPLUS + n°2 ELEXP
AUTOMATIC PUSH BUTTON	12	---	---	---	---
DOWN COLLECTIVE	12	24	---	---	32
FULL COLLECTIVE	12	---	18	24	30

*Table 1 – ELEMPU – ELEPLUS – ELEXP Configurations*

# 2 – DIMENSIONS AND FASTENING

**Dimensions:** 93 x 120 mm

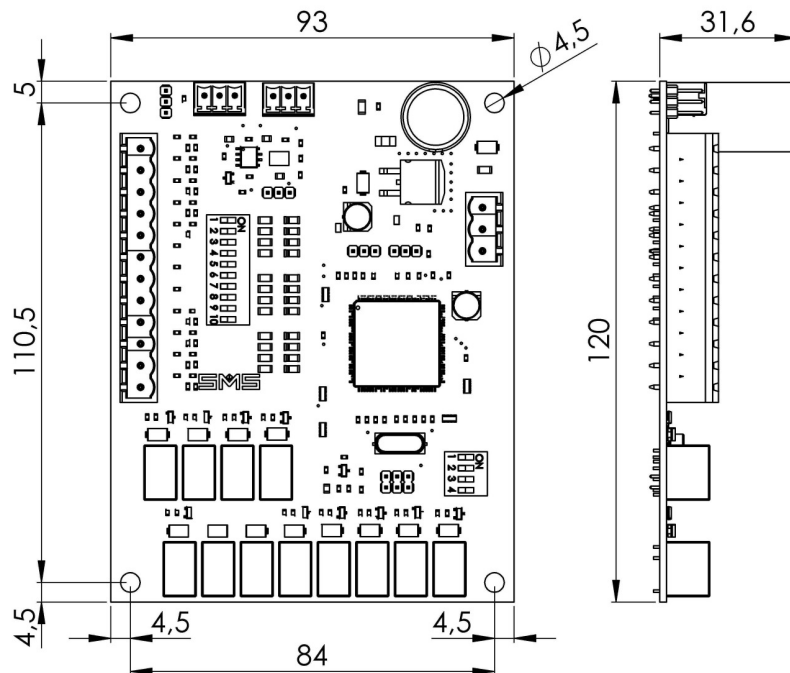

**Fig. 1**

### 3 – ELECTRICAL SPECIFICATIONS

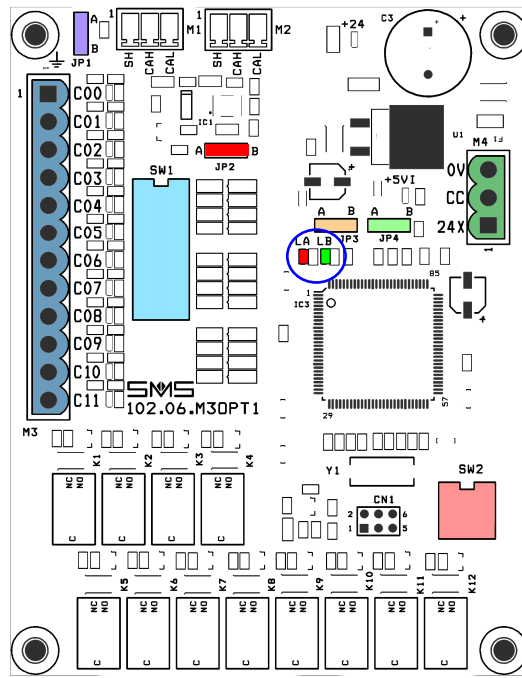

Fig. 2

#### SUPPLY VOLTAGE:

24vdc +/- 10% (terminals **24X - 0V~ / M4**), protected by 1A fuse.

#### IMPORTANT

Do not supply the board with a different voltage. In addition **the negative of the 24Vdc voltage (terminal 0V / M13) MUST NOT be connected to EARTH.**

#### SERIAL:

**CAN BUS Serial Port** for connection with ELEMPU or ELEPLUS Board (terminals **SH (shield)– CAH - CAL / M1 and M2**)

#### INPUTS

**N°12 Inputs 24Vdc** (Terminal Board M3), for car and landing call push-buttons.

All the input circuits are protected against line noises and voltage surges, and the status of each input is indicated by the corresponding Led.

#### OUTPUTS

**N°12 Relay Outputs:**

- “Registered” signals
- or - “7 segments” car position display control (9 outputs available)
- or - “1 output per floor” car position display control

**Dry contacts** are available in the terminal board, which have the following features:

- Switching power: 0.5A/125Vac AC1 1A/30Vdc DC1
- Max switching voltage (ac/dc): 125Vac/ 60Vdc

The common terminal for the position signal (terminal CC) is voltage free and must be connected as in the following, for each specific application.

#### SIGNALS

**Led LA RED** SLOW flashing The microprocessor is working  
**Led LB GREEN** FAST flashing The CAN communication is ON

#### SETTINGS

**SW1** N° 10 Switches for Input / Output splitting – Factory setting = All **ON**.

Move them all in **OFF** only in display mode, with POSITIVE (Anode) COMMON; in this case connect the terminal CC in M4 to 0V (see Cap. 5).

**SW2** N° 4 Addressing Switches – Factory setting = All **OFF**.

Switches 1 and 2: define the address of each single board (see Cap. 4-5-6),

Switches 3 and 4: used in case of MULTIPLEX operation only, to set the lift which the board refers to.

SW2-3	SW2-4	
OFF	OFF	LIFT 1
ON	OFF	LIFT 2
OFF	ON	LIFT 3
ON	ON	LIFT 4

- JP1** Jumper for CAN shield connection, to 0V or to EARTH  
**A** = shield connected to EARTH (factory setting)  
**B** = shield connected to 0V
- JP2** Bus Termination Jumper  
**A** = termination resistance NOT connected (factory setting)  
**B** = termination resistance connected, total resistance CAH-CAL = 120Ω  
 Connect the termination resistance on the other boards connected via CAN so that the resistance between CAH and CAL of the CAN BUS is 60Ω.
- JP3** Added Addressing Jumper  
 Factory setting = **A**  
 Move it to **B** only if JP4 = A and ELEMPU Function Top Floor > 23 (see Cap.4.1 & 4.2.4)
- JP4** Operating Mode Jumper  
**A** = Operating as car and landing call expansion (factory setting)  
**B** = All the other applications

## 4 – ELEXP AS EXPANSION CARD FOR CAR AND LANDING CALLS

### 4.1 – PARALLEL CONFIGURATION WITH THE ELEMPU BOARD

The ELEXP Board provides 12 Inputs / Outputs for the expansion of the car and landings calls, and their use depends on the collective operation type (down or full).

In detail:

- Down Collective Operation:  
 n°6 I/O car controls and n°6 I/O Down landing calls → + 6 stops
- Full Collective Operation:  
 n°4 I/O car controls - n°4 I/O Up landing calls - n°4 I/O down landing calls → + 4 stops

#### TERMINAL BOARD M3

LABEL	DOWN COLLECTIVE	FULL COLLECTIVE
C00	K/L n	K/L n
C01	K/L n	K/L n
C02	K/L n	K/L n
C03	K/L n	K/L n
C04	K/L n	U/L n
C05	K/L n	U/L n
C06	D/L n	U/L n
C07	D/L n	U/L n
C08	D/L n	D/L n
C09	D/L n	D/L n
C10	D/L n	D/L n
C11	D/L n	D/L n

#### SETTINGS:

F51 (ELEMPU)	CALLS ONLY
SW1	ALL ON
JP4	A

	1° ELEXP	2° ELEXP	3° ELEXP	4° ELEXP	5° ELEXP	6° ELEXP
SW2-1	OFF	ON	OFF	ON	OFF	ON
SW2-2	OFF	OFF	ON	ON	OFF	OFF
JP3	A	A	A	A	B	B

**Table 2**

KEY: K/L n = Car Control button for nth floor, with corresponding light  
 U/L n = Up Landing Call button at nth floor, with corresponding light  
 D/L n = Down Landing Call button at nth floor, with corresponding light

To each Cn terminal is linked the REGISTERD signal, which must be connected to the same terminal provided for the button, as shown in Figure 3 (only one wire for the connection of button/lamp to the board):

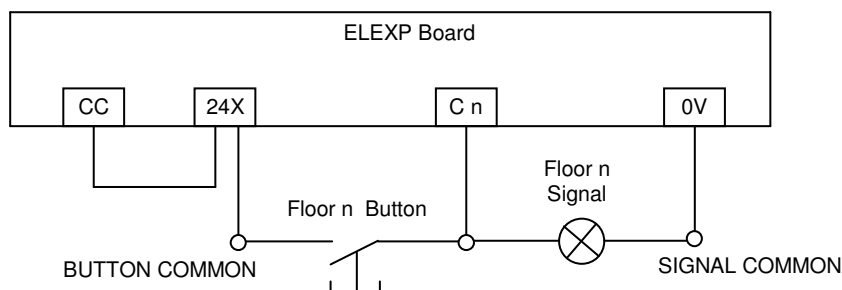

**Fig. 3**

## 4.2 – CONFIGURATION WITH SERIAL CONNECTION TO THE CAR (ELEMPU + ELEPLUS BOARDS)

Also in this case the ELEXP board provides 12 Inputs / Outputs for the expansion of the car and landings calls, but it shall be considered that 12 car controls for the first twelve floors are always managed by the ELEPLUS board.

The ELEXP board works in the same way as the ELEPLUS, when used as call expansion.

The following Tables replace the ones in the ELESYS User's Manual at:

Cap.15 – LANDING CALL AND CAR CALL CONNECTIONS FOR LIFT SYSTEMS WITH COLLECTIVE OPERATION AND STOP N° > 12

For the connections, please refer to the previous Fig.3.

### GENERAL SETTINGS:

F51 (ELEMPU)	CAR & CALLS
SW1	ALL ON
JP4	A

### 4.2.1 - DOWN COLLECTIVE UP TO 24 STOPS

#### ELEMPU

LABEL	FUNCTION
U00	U/L 0
U01	D/L 1
U02	D/L 2
U03	D/L 3
U04	D/L 4
U05	D/L 5
U06	D/L 6
U07	D/L 7
U08	D/L 8
U09	D/L 9
U10	D/L 10
U11	D/L 11
D00	D/L 12
D01	D/L 13
D02	D/L 14
D03	D/L 15
D04	D/L 16
D05	D/L 17
D06	D/L 18
D07	D/L 19
D08	D/L 20
D09	D/L 21
D10	D/L 22
D11	D/L 23

#### ELEPLUS

LABEL	FUNCTION
C00	K/L 0
C01	K/L 1
C02	K/L 2
C03	K/L 3
C04	K/L 4
C05	K/L 5
C06	K/L 6
C07	K/L 7
C08	K/L 8
C09	K/L 9
C10	K/L 10
C11	K/L 11
SW1-1	= OFF
SW1-2	= OFF

#### ELEXP N°1

LABEL	FUNCTION
C00	K/L 12
C01	K/L 13
C02	K/L 14
C03	K/L 15
C04	K/L 16
C05	K/L 17
C06	K/L 18
C07	K/L 19
C08	K/L 20
C09	K/L 21
C10	K/L 22
C11	K/L 23
SW2-1	= ON
SW2-2	= OFF
JP3	= A

KEY: K/L n = Car Control button for nth floor, with corresponding light  
 U/L n = Up Landing Call button at nth floor, with corresponding light  
 D/L n = Down Landing Call button at nth floor, with corresponding light

**Table 3 – Configuration of Landing calls and Car controls - Down Collective 24 Stops**

## 4.2.2 - FULL COLLECTIVE UP TO 18 STOPS

### ELEMPU

LABEL	FUNCTION
U00	U/L 0
U01	U/L 1
U02	U/L 2
U03	U/L 3
U04	U/L 4
U05	U/L 5
U06	U/L 6
U07	U/L 7
U08	U/L 8
U09	U/L 9
U10	U/L 10
U11	U/L 11
D00	
D01	D/L 1
D02	D/L 2
D03	D/L 3
D04	D/L 4
D05	D/L 5
D06	D/L 6
D07	D/L 7
D08	D/L 8
D09	D/L 9
D10	D/L 10
D11	D/L 11

### ELEPLUS

LABEL	FUNCTION
C00	K/L 0
C01	K/L 1
C02	K/L 2
C03	K/L 3
C04	K/L 4
C05	K/L 5
C06	K/L 6
C07	K/L 7
C08	K/L 8
C09	K/L 9
C10	K/L 10
C11	K/L 11
SW1-1	= OFF
SW1-2	= OFF

### ELEXP N°1

LABEL	FUNCTION
C00	K/L 12
C01	K/L 13
C02	K/L 14
C03	K/L 15
C04	K/L 16
C05	K/L 17
C06	K/L 18
C07	K/L 19
C08	K/L 20
C09	K/L 21
C10	K/L 22
C11	K/L 23
SW2-1	= ON
SW2-2	= OFF
JP3	= A

### ELEXP N°2

LABEL	FUNCTION
U00	U/L 12
U01	U/L 13
U02	U/L 14
U03	U/L 15
U04	U/L 16
U05	
U06	D/L 12
U07	D/L 13
U08	D/L 14
U09	D/L 15
U10	D/L 16
U11	D/L 17
SW2-1	= OFF
SW2-2	= ON
JP3	= A

KEY: K/L n = Car Control button for nth floor, with corresponding light  
 U/L n = Up Landing Call button at nth floor, with corresponding light  
 D/L n = Down Landing Call button at nth floor, with corresponding light

**Table 4 – Configuration of Landing calls and Car controls - Full Collective 18 Stops**

### 4.2.3 - FULL COLLECTIVE UP TO 24 STOPS

#### ELEMPU

LABEL	FUNCTION
U00	U/L 0
U01	U/L 1
U02	U/L 2
U03	U/L 3
U04	U/L 4
U05	U/L 5
U06	U/L 6
U07	U/L 7
U08	U/L 8
U09	U/L 9
U10	U/L 10
U11	U/L 11
D00	
D01	D/L 1
D02	D/L 2
D03	D/L 3
D04	D/L 4
D05	D/L 5
D06	D/L 6
D07	D/L 7
D08	D/L 8
D09	D/L 9
D10	D/L 10
D11	D/L 11

#### ELEPLUS

LABEL	FUNCTION
C00	K/L 0
C01	K/L 1
C02	K/L 2
C03	K/L 3
C04	K/L 4
C05	K/L 5
C06	K/L 6
C07	K/L 7
C08	K/L 8
C09	K/L 9
C10	K/L 10
C11	K/L 11
SW1-1	= OFF
SW1-2	= OFF

#### ELEXP N°1

LABEL	FUNCTION
C00	K/L 12
C01	K/L 13
C02	K/L 14
C03	K/L 15
C04	K/L 16
C05	K/L 17
C06	K/L 18
C07	K/L 19
C08	K/L 20
C09	K/L 21
C10	K/L 22
C11	K/L 23
SW2-1	= ON
SW2-2	= OFF
JP3	= A

#### ELEXP N°2

LABEL	FUNCTION
U00	U/L 12
U01	U/L 13
U02	U/L 14
U03	U/L 15
U04	U/L 16
U05	U/L 17
U06	U/L 18
U07	U/L 19
U08	U/L 20
U09	U/L 21
U10	U/L 22
U11	
SW2-1	= OFF
SW2-2	= ON
JP3	= A

#### ELEXP N°3

LABEL	FUNCTION
U00	D/L 12
U01	D/L 13
U02	D/L 14
U03	D/L 15
U04	D/L 16
U05	D/L 17
U06	D/L 18
U07	D/L 19
U08	D/L 20
U09	D/L 21
U10	D/L 22
U11	D/L 23
SW2-1	= ON
SW2-2	= ON
JP3	= A

KEY: K/L n = Car Control button for nth floor, with corresponding light  
 U/L n = Up Landing Call button at nth floor, with corresponding light  
 D/L n = Down Landing Call button at nth floor, with corresponding light

**Table 5 – Configuration of Landing calls and Car controls - Full Collective 24 Stops**



#### 4.2.4 - FULL COLLECTIVE UP TO 32 STOPS

##### ELEMPU

LABEL	FUNCTION
U00	U/L 0
U01	U/L 1
U02	U/L 2
U03	U/L 3
U04	U/L 4
U05	U/L 5
U06	U/L 6
U07	U/L 7
U08	U/L 8
U09	U/L 9
U10	U/L 10
U11	U/L 11
D00	
D01	D/L 1
D02	D/L 2
D03	D/L 3
D04	D/L 4
D05	D/L 5
D06	D/L 6
D07	D/L 7
D08	D/L 8
D09	D/L 9
D10	D/L 10
D11	D/L 11

##### ELEPLUS

LABEL	FUNZIONE
C00	K/L 0
C01	K/L 1
C02	K/L 2
C03	K/L 3
C04	K/L 4
C05	K/L 5
C06	K/L 6
C07	K/L 7
C08	K/L 8
C09	K/L 9
C10	K/L 10
C11	K/L 11
SW1-1	= OFF
SW1-2	= OFF

##### ELEXP N°1

LABEL	FUNCTION
C00	K/L 12
C01	K/L 13
C02	K/L 14
C03	K/L 15
C04	K/L 16
C05	K/L 17
C06	K/L 18
C07	K/L 19
C08	K/L 20
C09	K/L 21
C10	K/L 22
C11	K/L 23
SW2-1	= ON
SW2-2	= OFF
JP3	= A

##### ELEXP N°3

LABEL	FUNCTION
U00	U/L 12
U01	U/L 13
U02	U/L 14
U03	U/L 15
U04	U/L 16
U05	U/L 17
U06	U/L 18
U07	U/L 19
U08	U/L 20
U09	U/L 21
U10	U/L 22
U11	U/L 23
SW2-1	= ON
SW2-2	= ON
JP3	= A

##### ELEXP N°5

LABEL	FUNCTION
U00	D/L 12
U01	D/L 13
U02	D/L 14
U03	D/L 15
U04	D/L 16
U05	D/L 17
U06	D/L 18
U07	D/L 19
U08	D/L 20
U09	D/L 21
U10	D/L 22
U11	D/L 23
SW2-1	= ON
SW2-2	= OFF
JP3	= B

##### ELEXP N°2

LABEL	FUNCTION
C00	K/L 24
C01	K/L 25
C02	K/L 26
C03	K/L 27
C04	K/L 28
C05	K/L 29
C06	K/L 30
C07	K/L 31
C08	
C09	
C10	
C11	
SW2-1	= OFF
SW2-2	= ON
JP3	= A

##### ELEXP N°4

LABEL	FUNCTION
C00	U/L 24
C01	U/L 25
C02	U/L 26
C03	U/L 27
C04	U/L 28
C05	U/L 29
C06	U/L 30
C07	
C08	
C09	
C10	
C11	
SW2-1	= OFF
SW2-2	= OFF
JP3	= B

##### ELEXP N°6

LABEL	FUNCTION
U00	D/L 24
U01	D/L 25
U02	D/L 26
U03	D/L 27
U04	D/L 28
U05	D/L 29
U06	D/L 30
U07	D/L 31
U08	
U09	
U10	
U11	
SW2-1	= OFF
SW2-2	= ON
JP3	= B

KEY: K/L n = Car Control button for nth floor, with corresponding light  
 U/L n = Up Landing Call button at nth floor, with corresponding light  
 D/L n = Down Landing Call button at nth floor, with corresponding light

**Table 6 – Configuration of Landing calls and Car controls - Full Collective 32 Stops**

## 5 – ELEXP AS DECODER FOR “7 SEGMENTS” DISPLAY

The ELEXP Board provides 9 outputs to control a “7 segment” display, consisting of 2 digits (where the tens digit can assume only the value “1”) and the “minus” sign.

ELEXP can manage both POSITIVE COMMON displays and NEGATIVE COMMON displays.

### SETTINGS:

Function <b>F53</b> (ELEMPU) =	<b>7 SEG</b> or <b>7 SEG X 2</b> If it is set “7 SEG X2”, it is enabled an other ELEXP board with the same function, to control both the display in the car and the one at main floor.  ELEXP N°1: SW2-1 = OFF      ELEXP N°2: SW2-1 = ON SW2-2 = OFF                              SW2-2 = OFF
<b>SW1</b> (n° 10 Switches) =	ALL <b>OFF</b> in case of <u>POSITIVE COMMON</u> Display ALL <b>ON</b> all the other cases
<b>JP3</b> =	<b>A</b>
<b>JP4</b> =	<b>B</b>

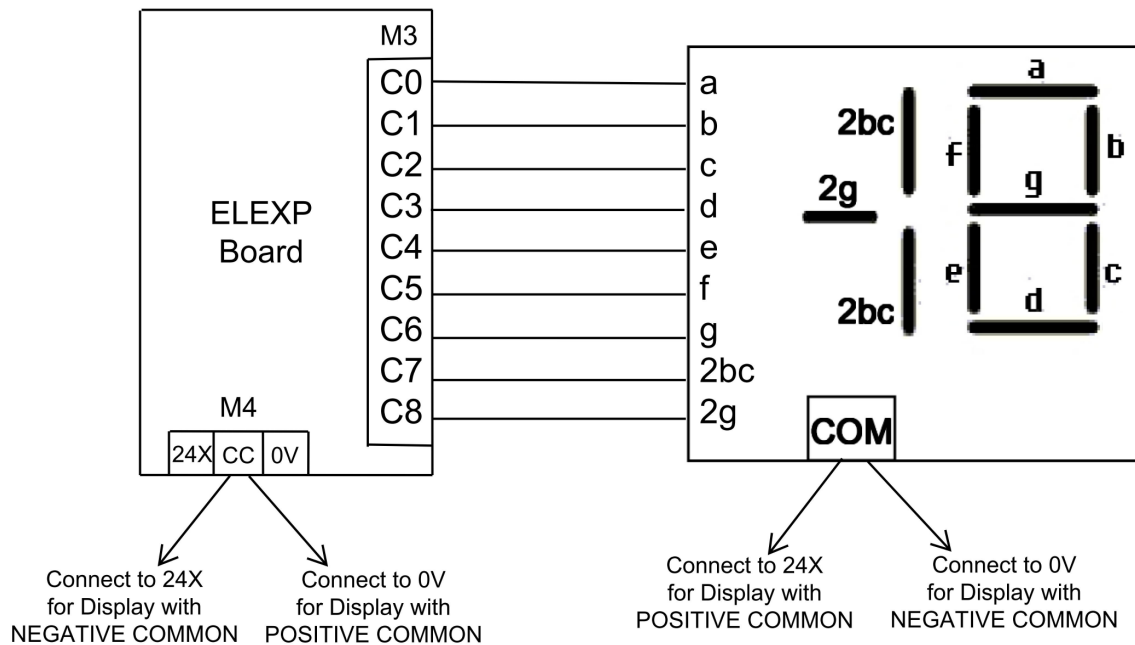

**Fig. 4**

## 6 – ELEXP AS DECODER FOR “1 INPUT PER FLOOR” DISPLAY

The ELEXP Board provides 12 outputs to control a display with 1 Input per floor, and NEGATIVE COMMON. In the same way, it's possible to control car position signals by lamps.

### SETTINGS:

Function <b>F53</b> (ELEMPU) =	<b>1 OUT X FLOOR</b> In this case it is enabled only one board if the lift stop number i(F) is ≤12, 2 boards if F > 13 and ≤ 24, 3 boards if F > 24 and ≤ 32.  ELEXP N°1.: SW2-1 = OFF      SW2-2 = OFF      ELEXP N°2: SW2-1 = ON      SW2-2 = OFF      ELEXP N°3: SW2-1 = OFF      SW2-2 = ON
<b>SW1</b> (n° 10 Switches) =	<b>ALL ON</b>
<b>JP3</b> =	<b>A</b>
<b>JP4</b> =	<b>B</b>

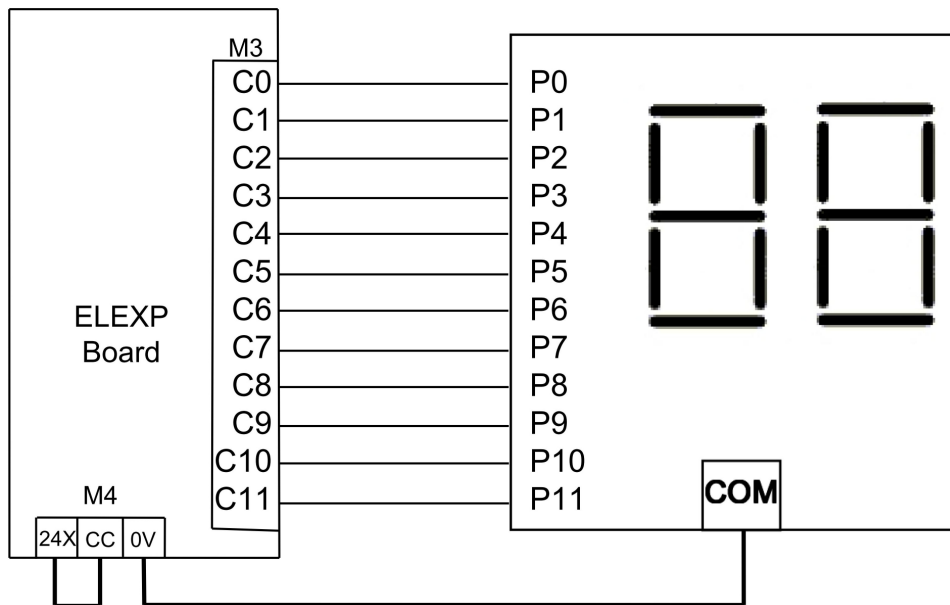

Fig. 5

For further information and advice contact:

**SMS SISTEMI e MICROSISTEMI s.r.l. (SASSI HOLDING Group)**  
Via Guido Rossa, 46/48/50 Loc. Crespellano 40053 Valsamoggia BO - ITALIA  
Tel. : +39 051 969037 Fax : +39 051 969303 Technical Service: +39 051 6720710  
E-mail : sms@sms.bo.it Internet : [www.sms-lift.com](http://www.sms-lift.com)